

GeNetix

User Manual

Installation, Operation Manual & Warranty Details

ChamSys Support - support@chamsys.co.uk

Firmware Version v2.00, 2024-08-21

Contents

Edition Notes	1
Trademarks	1
Copyright Notice	1
Manual Use	1
Intended Audience	1
Disclaimer	1
Care of Your GeNetix Product	2
Safety Notes	2
Using This Manual	3
1. GeNetix Products	4
GeNetix Package Contents	4
GeNetix Philosophy	5
GeNetix Network Nodes	6
GeNetix Quick Start	8
2. Connections	10
GeNetix Nodes	10
USB Connection	12
GW2I / GW2O	13
GeNetix Switches	13
GeNetix DMX Splitters	15
GeNetix 10Scene Interfaces	15
3. Node Navigation	18
Node Encoders & Buttons	18
Node Home Display	18
Menu Navigation	19
4. Quick Setup	20
5. IP Setup	21
6. Protocol	22
7. Start Universe	23
8. Ports	24
Port Configuration	24
DMX Fallback	25
DMX Merging	26
DMX Port LEDs	27
9. Scenes	29
Configuring Scenes	29
Controlling Scenes	30
10. System	31
Lost Data Input	31

Sync Mode	31
RDM	32
DMX Timings	32
Lock	32
Node Name	33
Factory Reset	33
11. User Configs	34
12. 10Scene	35
10Scene External Control	35
13. Contact Triggers	37
Trigger Mode	37
Trigger Scene	37
14. MIDI & Timecode	38
Timecode	38
MIDI	38
15. MagicQ Configuration	40
Devices View	40
Ports View	44
Options View	44
Scenes View	45
16. Web Server Configuration	46
System Overview	46
Device	47
Network	47
Ports	48
DMX Timing	49
Scenes	49
User Configs	50
Help	50
PIN Locking / Unlocking	51
Error Messages	51
17. Feature Comparison	52
GeNetix Nodes Comparison	52
GeNetix Switches Comparison	53
18. 3rd Party Console Support	54
3rd Party Consoles Support with GeNetix Nodes	54
19. GeNetix Firmware Release Notes	56
Version 2.00	56
Version 1.04	56
Version 1.01	56
20. Firmware Upgrade	57

Glossary	58
Appendix A: DMX, Ethernet and Art-Net	60
DMX	60
Ethernet	60
Art-Net	60
Appendix B: FCC Part 15 Notice	62
Appendix C: Disposal and Recycling of Unwanted Consoles	63
Appendix D: GeNetix Warranty Certificate	64

Edition Notes

This GeNetix User Manual includes a description, safety precautions, installation, and operation instructions for the GeNetix series of networking products as of the release date of this edition.

ChamSys continually strives to provide the most powerful and stable solution for all of our GeNetix products. As such, we are making continual improvements to the software & firmware available to all of our users. To unlock the full potential of your product we suggest downloading and installing the latest MagicQ and/or QuickQ software to update your GeNetix device.

Detailed installation & update instructions can be found in the [updating GeNetix firmware](#) section.

Trademarks

ChamSys, the ChamSys logo and GeNetix are registered trademarks or trademarks of ChamSys Ltd in the United Kingdom and other countries. Other company and product names and logos referred to herein may be trademarks of their respective companies.

Copyright Notice

The works of authorship contained in this manual, including, but not limited to, all design, text and images are owned by ChamSys Ltd. All rights reserved.

Manual Use

ChamSys authorises its customers to download and print this manual for professional information purposes only. ChamSys expressly prohibits the usage, copy, storage, distribution, modification, or printing of this manual or its content for any other purpose without written consent from ChamSys

Intended Audience

Any person installing, operating, and/or maintaining this product should completely read through the guide that shipped with the product, as well as this manual, before installing, operating, or maintaining this product.

Disclaimer

ChamSys believes that the information contained in this manual is accurate in all respects. However, ChamSys assumes no responsibility and specifically disclaims any and all liability to any party for any loss, damage or disruption caused by any errors or omissions in this document, whether such errors or omissions result from negligence, accident or any other cause. ChamSys reserves the right to revise the content of this document without any obligation to notify any person or company of such revision, however, ChamSys has no obligation to make, and does not commit to make, any such revisions. Download the latest version from <https://secure.chamsys.co.uk>.

Care of Your GeNetix Product

To keep your GeNetix Product in best condition please observe the following recommendations:

- Keep liquids away from the GeNetix Product. Drinks spilled over a GeNetix Product may cause irreparable damage.
- Keep the GeNetix Product out of direct sunlight - place the GeNetix Product in the shade.
- Do not block the ventilation grills on the rear panel, side, and underneath the GeNetix Product.
- Do not use the GeNetix Product outside its operating temperature range.
- Handle the GeNetix Product with care when moving or transporting it. The GeNetix Product contains components that may be damaged by shock. Always use a padded flight case wherever possible.
- Do not use solvents or cleaners to clean the GeNetix Product. Do not rub firmly on the metal or plastic surfaces - this may cause the paint or lettering to be removed. Gently use a damp cloth to clean the panels.

Safety Notes

- Do not open the GeNetix Product unless you are a skilled person authorised and trained by ChamSys in GeNetix Product maintenance and repair. The GeNetix Product contains components with voltages that may shock.
- Do not use the GeNetix Product if the power cables are damaged in any way.
- Repairs should only be undertaken by authorised service representatives. There are no user serviceable parts inside the GeNetix Product.
- If liquids are spilt over the GeNetix Product then remove power immediately, and seek advice from your authorised service representative.
- When transporting the GeNetix Product ensure that there are sufficient people to carry the GeNetix Product.
- Ensure safe installation of GeNetix Products, so that the unit cannot slip off or fall from its operated position.

Using This Manual



Indicates some useful information to add to your knowledge and experience.



Indicates some additional information that may be relevant.



A Warning statement indicates situations where damage may occur, people may be harmed, or there are serious or dangerous consequences of an action.



A Caution statement indicates there may be unwanted or undefined consequences of an action, or potential for programmed data loss or an equipment problem.

Chapter 1. GeNetix Products

The GeNetix Product range includes:

GeNetix GS5IP	5 port IP rated Gigabit network switch. AC or PoE powered.
GeNetix GS8	8 port PoE sourcing Gigabit network switch. 4 ports PoE++ 4 ports PoE+. AC powered.
GeNetix GW20	2 port wall mount DMX node with 5 pin female XLR connectors. Connect via network with PoE.
GeNetix GW2I	2 port wall mount DMX node with 5 pin male XLR connectors. Connect via network with PoE.
GeNetix GN2	2 port DMX node box. Front panel display. Connect via network or direct to MagicQ PC via USB. Powered via USB or PoE.
GeNetix GN5	5 port DMX node with MIDI, Timecode and 10Scene. Front panel display. Connect via network or direct to MagicQ PC via USB. Powered via AC or PoE.
GeNetix GN10	10 port rack mount DMX node with MIDI, Timecode and 10Scene. Front panel display. Connect via network or direct to MagicQ PC via USB. Powered via AC or PoE.
GeNetix 10Scene Store	Simple Store and Playback of 10 static Lighting scenes. 48v or PoE powered, DMX output and 10Scene Wall Plate support
GeNetix GD4IP	Compact 4-port IP65-rated DMX Splitter that features a single DMX Input to 4 DMX outputs.

The GS5IP and GS10 are simple unmanaged gigabit network switches and therefore there is no configuration required.

GD4IP splitters also require no configuration as all output ports will duplicate any data received from the input port.

GW20, GW2I, GN2, GN5, and GN10 network nodes are highly configurable from MagicQ and QuickQ consoles, and also via the onboard web interface. GN2, GN5, GN10 also can be configured from their inbuilt front panel.

GeNetix Package Contents

GeNetix products ship with the following package contents:

GeNetix GS5IP	<ul style="list-style-type: none"> • PowerCON TRUE1 Cable • Quick Start Guide
GeNetix GS8	<ul style="list-style-type: none"> • PowerCON TRUE1 Cable • Quick Start Guide • Pair of GeNetix Rack Ears
GeNetix GW20	<ul style="list-style-type: none"> • Quick Start Guide • White Faceplate
GeNetix GW2I	<ul style="list-style-type: none"> • Quick Start Guide • White Faceplate
GeNetix GN2	<ul style="list-style-type: none"> • USB-C Cable • Quick Start Guide • DIN Rail Mount • Set of Rubber Feet
GeNetix GN5	<ul style="list-style-type: none"> • PowerCON TRUE1 Cable • Quick Start Guide • DIN Rail Mount • 10Scene Connector • Pair of GeNetix Rack Ears • Set of Rubber Feet
GeNetix GN10	<ul style="list-style-type: none"> • PowerCON TRUE1 Cable • Quick Start Guide • 10Scene Connector • Set of Rubber Feet
GeNetix 10Scene Store	<ul style="list-style-type: none"> • DIN Rail Mount • Set of Rubber Feet
GeNetix GD4IP	<ul style="list-style-type: none"> • PowerCON TRUE1 cable • Quick Start Guide

GeNetix Philosophy

GeNetix network products enable DMX data, media data and control data to be distributed throughout the lighting rig from control consoles to fixtures. GeNetix products can be used with any lighting console or media server - they are independent of MagicQ and QuickQ products.

GeNetix products are designed and engineered in the UK by ChamSys Ltd, and are designed for reliability. Wherever possible, all components are mounted on a single circuit board to avoid the need for interconnecting cables.

GeNetix products use professional locking Ethercon connectors for all network connections, avoiding the limited lifetime associated with traditional RJ45 network plugs and sockets.

GeNetix GN5, GN10, G55IP, GD4IP and G58 use professional locking power connectors for power input and accept voltages from 90V to 250V AC.

GeNetix products support being powered via Power over Ethernet (PoE) - the GeNetix GW20, GW2I, GN2, GN5, GN10 and 10Scene Store can be powered directly by their PoE input (such as from the GeNetix G58) reducing the number of cables in a system.

GeNetix Network Nodes

The GW20, GW2I, GN2, GN5 and GN10 make up the network nodes in the GeNetix range.

All GeNetix network nodes support the following:

- DMX512 out and in
- Configurable DMX timings
- ANSI E1.20 RDM
- Art-Net 4
- sACN (streaming ACN) including priorities
- DMX Test pattern generation
- DMX Synchronisation between ports and devices
- DMX Fallback mode (DMX loops in and out)
- DMX Merging of multiple sources through a single port
- Configurable Lost Network behaviour
- Storage of Scenes
- Record and Playback Scenes from MagicQ / QuickQ console
- Send / Retrieve Scenes from MagicQ console
- Identify mode
- Configuration from MagicQ and QuickQ consoles and systems over ChamNet
- Configuration from web server
- Configuration over Art-Net (DMX port configuration only)
- Saving, Loading and Resetting of User Configs
- Factory Presets (standard node setups, for example: Art-Net 0..9)
- Factory Reset
- Locking / unlocking of the node
- Firmware update (from MagicQ and QuickQ)

GN5 & GN10 Additional Features

The GeNetix GN5 and GN10 provide the following additional features:

- LTC timecode in and out
- MIDI timecode in and out
- MIDI notes in and out
- MIDI beat clock
- MIDI change control and system exclusive messages
- Trigger of Scenes from 10Scene Wall Plates
- Trigger of Configs from 10Scene Wall Plates
- 10Scene Gateway functionality

Networking

GeNetix products support Art-Net 4, along with ACN Streaming DMX network protocols. The DMX512 ports are fully configurable with DMX packet length, framing rate, and timings.

All GeNetix products ship with a 10.X.X.X IP address and 255.0.0.0 Subnet Mask as standard. For most situations when just connecting a single GeNetix product to a MagicQ or QuickQ console this IP address does not need to be changed.

It is important that any consoles, PCs or Macs that will be communicating with GeNetix products are set with a static IP addresses within the IP address range that is set on the GeNetix.

GeNetix products have inbuilt Ethernet switches with auto MDI/MDIX detection, so when connecting directly between a PC/Console and GeNetix products a cross over Ethernet cable is not required.

If you change the IP address of the GeNetix product it will not show up again in Net Manager until you have reconfigured the network on your system to be within the same range as the Interface.

Unlocking MagicQ

GeNetix GN5 and GN10 nodes fully unlock MagicQ PC/Mac Software when connected over USB or network.

GeNetix GN2 nodes unlock MagicQ PC/Mac Software into Core mode when connected over USB or network.

GeNetix 10Scene Store, GD4IP, G55IP, G58, GW2I and GW2O do not unlock MagicQ at all.

Configurable DMX Timings

The DMX refresh rate, break time, frame time and MAB time are fully configurable.

Configuration is from the front panel, MagicQ Net Manager, via Art-Net and also from the web server.

ANSI E1.20 RDM

GeNetix network nodes support RDM which is enabled by default.

The GeNetix nodes only perform RDM operations when requested by the MagicQ or QuickQ console. They do not perform discovery on start up, or at predefined intervals - they only perform RDM discovery when explicitly requested by the console. This ensures that show critical DMX operation is not affected by RDM.

RDM on the node can be disabled on a menu option from the front panel and from the MagicQ console.

The node can also be set into a RDM Read Only mode. In this mode the GeNetix node will respond to RDM GET commands to receive information but will block all RDM SET commands. This enables users to discover the lighting rig, but not to change it.

Art-Net Support

GeNetix network nodes support Art-Net V1,2,3 and 4.

They will respond to an Art-Poll with an Art-Poll Reply in Art-Net V4 format.

The node IP address, subnet mask and node name can be configured over Art-Net.

The port protocol, universe and direction can be configured over Art-Net. The node name and IP Address can also be set over Art-Net.

sACN Support

GeNetix network nodes fully support sACN. GeNetix nodes join multicast groups as per the specification.

The nodes handle sACN priorities on a per universe basis. Sources for a particular universe will be timed out after 5 seconds of not receiving any sACN data from that source.

GeNetix Quick Start

GeNetix nodes offer quick setup options for common user scenarios.

To ensure connection to GeNetix products users must ensure the device is in the same IP range as the lighting controller.

Common Scenario 1: Receiving Art-Net

GeNetix Nodes are capable of receiving Art-Net from a lighting console and outputting DMX. Users can accomplish this by navigating to the Quick Setup option on the Main Menu of the GeNetix Node.

Users have four options for quick setup in regards to Art-Net output:

- GeNetix node Ports will output starting from Art-Net Universe 0
- GeNetix node Ports will output starting from Art-Net Universe 1

- All ports output Art-Net Universe 0
- All ports output Art-Net Universe 1

Common Scenario 2: Receiving sACN

GeNetix Nodes are capable of receiving sACN from a lighting console and outputting DMX. Users can accomplish this by navigating to the Quick Setup option on the Main Menu of the GeNetix Node.

Users have two options for quick setup in regards to sACN output:

- GeNetix node Ports will output starting from Universe 1
- All ports output sACN Universe 1

For finer control of the starting universe for the GeNetix node users can navigate to the Starting Universe option on the main menu, there the user can adjust the starting universe through use of the encoder.



Ports will increase sequentially from the starting universe number set.

Common Scenario 3: Receive Art-Net, Output DMX and Input received LTC timecode from the GeNetix Node to the lighting console

GeNetix Nodes are capable of receiving and outputting LTC or MIDI timecode whilst simultaneously outputting DMX.

For ease of use it's recommended to use the previously mentioned quick setup to assign the ports on the GeNetix node to output through either Art-Net or sACN.

- Connect LTC/MIDI generation device to the corresponding port on the back of the GeNetix Node.
- Navigate from the GeNetix node main menu to Timecode > IN > Mode and select Art-Net.
- Ensure Timecode > OUT > Mode is disabled.
- Ensure a network cable is connected between the GeNetix Node and either a lighting console or PC/Mac running MagicQ.
- In MagicQ navigate to Setup > View Settings > MIDI Timecode and set Timecode Decode to Art-Net



LTC/MIDI timecode is available on the GN5 and GN10. The GN2 is not able to receive or output LTC/MIDI.

Chapter 2. Connections

GeNetix Nodes

GeNetix Nodes all support industry standard protocols Art-Net and sACN supporting DMX Output or DMX Input, GeNetix nodes differ in the number of DMX ports. GeNetix GN2, GN5 and GN10 all feature an inbuilt display for node configuration and displaying device status. The GeNetix GN5 and GN10 feature additional connections supporting MIDI, Timecode and 10Scene.

All GeNetix Nodes can be powered via PoE, with the GN2, GN5 and GN10 supporting PoE Mode A and Mode B. The GW2I and GW2O nodes are powered only via PoE, supporting Mode A only (PoE over the data pair). In addition to PoE power, the GN2 can be USB powered via it's USB-C port. The GN5 and GN10 can in addition to being PoE powered be mains powered via their mains Line Input.

GN2

The GN2 can operate as an Art-Net or sACN Node utilising it's network connection or can also be used as a USB-DMX interface for MagicQ PC Systems. The GN2 will unlock MagicQ PC Systems when connected via either USB or Network into 'Core Mode'.



When unlocking PC based systems via Network, there is a limit of 2 MagicQ sessions in the network. When a 3rd MagicQ instance is connected (this could be a console or another PC system), network unlock for all devices will be stopped.

The GN2 can be either PoE powered or powered via it's USB-C port.

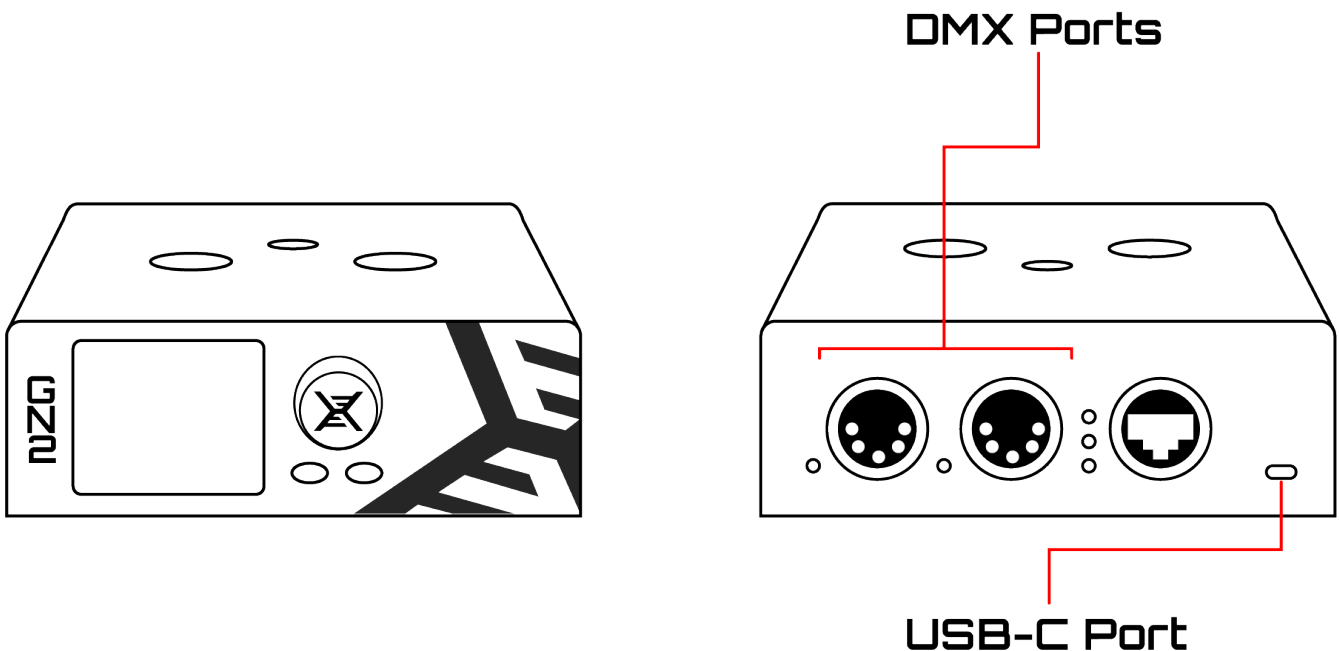

The GN2 can run in network mode but still be powered from USB - provided that it is not connected to a PC running MagicQ - if MagicQ is detected it will be switched to USB mode.



GN5

The GN5 operates as an Art-Net or sACN Node utilising it's network connection or can also be used as a USB-DMX interface for MagicQ PC Systems. The GN5 will unlock MagicQ PC Systems when connected via either USB or Network into Full 'Unlocked Mode'.



When unlocking PC based systems via Network, there is a limit of 2 MagicQ sessions in the network. When a 3rd MagicQ instance is connected (this could be a console or another PC system), network unlock for all devices will be stopped.

The GN5 can be either PoE powered or mains powered. When connecting to a MagicQ PC system via USB, the unit must be either Mains or PoE powered.

GeNetix GN5 Node

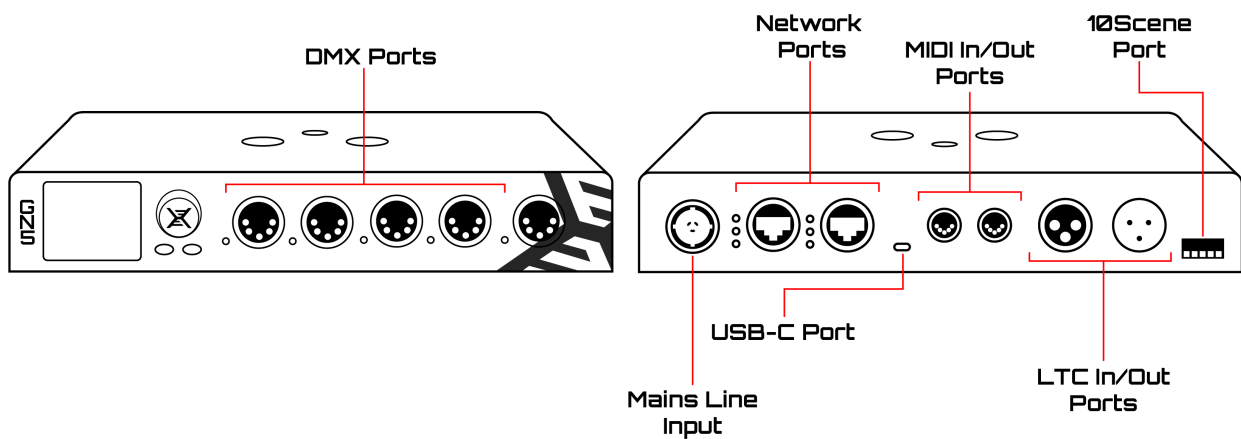

GN10

The GN10 operates as an Art-Net or sACN Node utilising it's network connection or can also be used as a USB-DMX interface for MagicQ PC Systems. The GN10 will unlock MagicQ PC Systems when connected via either USB or Network into Full 'Unlocked Mode'.



When unlocking PC based systems via Network, there is a limit of 2 MagicQ sessions in the network. When a 3rd MagicQ instance is connected (this could be a console or another PC system), network unlock for all devices will be stopped.

The GN10 can be either PoE powered or mains powered. When connecting to a MagicQ PC system via USB, the unit must be either Mains or PoE powered.

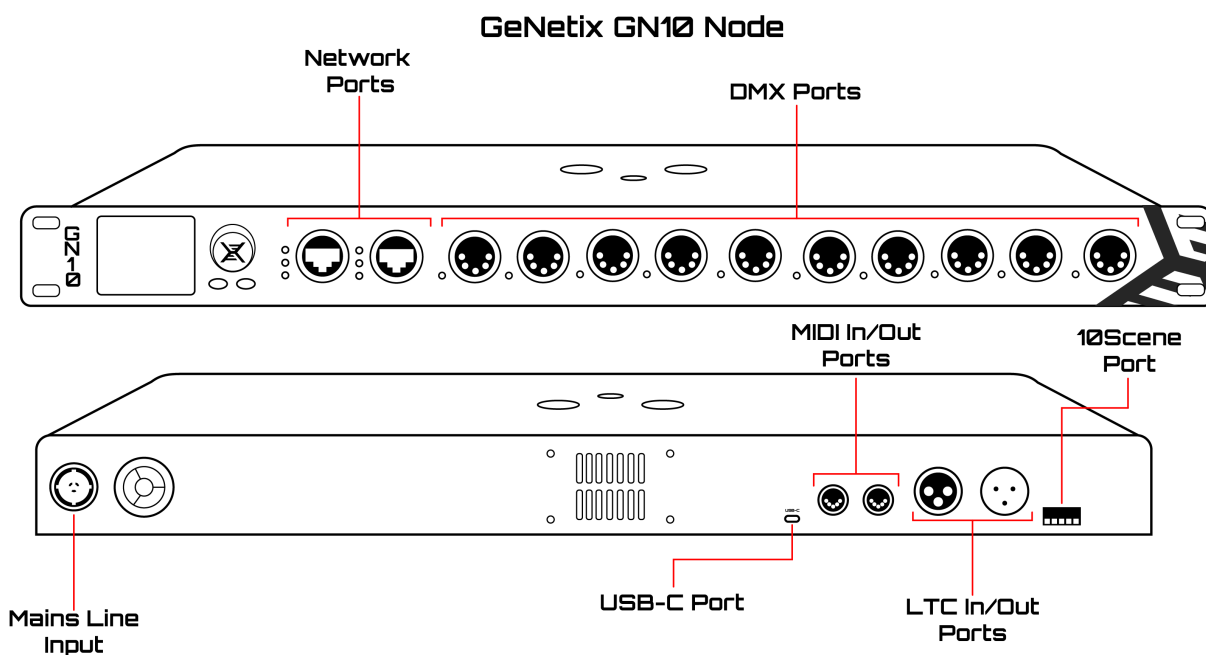

USB Connection

The GN2, GN5 and GN10 have an optional USB connection, allowing them to be used in either USB or Network mode.

When a GeNetix node is connected via USB to a PC (Windows, Mac or Linux) with MagicQ running then the GeNetix node runs in USB mode, functioning as a MagicQ interface connected directly to the MagicQ application.

In USB mode it is treated just like a MagicQ Wing or Interface with the configuration being controlled from within MagicQ rather than from the GeNetix node. In this mode the node configuration is unused, although it is retained for when the node is used again in Network mode.

When in USB mode, the DMX outputs are configured in MagicQ from the Setup Window, VIEW DMX I/O. For GN5 and GN10 the MIDI, Timecode and 10Scene port are configured in MagicQ from the Setup Window, VIEW SETTINGS. The configuration is stored in the MagicQ show file as normal.

The node indicates USB mode on its front panel when in USB mode.

The node continues in USB mode even if the USB link is lost or MagicQ is stopped. To restart the node in Network mode, disconnect the USB or shut down the MagicQ and then power the GeNetix node on and off.



Note that firmware upgrade is only supported over ChamNet, not over USB. Firmware upgrade can be carried out from the free MagicQ PC/Mac software, and from MagicQ and QuickQ consoles.

GW2I / GW20

GW2I / GW20 Wiring

The GW2I and GW20 nodes are wired using either Cat5e or Cat6 cable using their punch down terminals. When wired via T568B wiring the GW2's are wired as shown below:

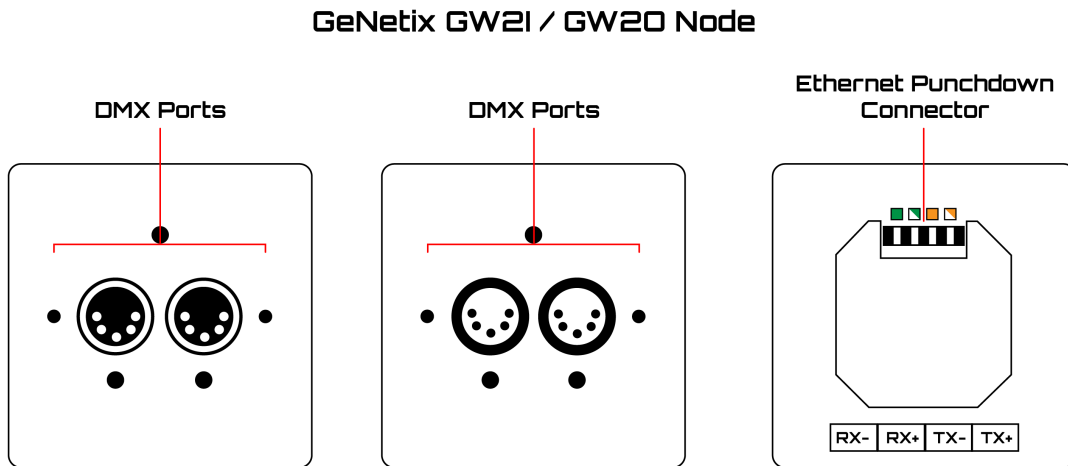

When using PoE injectors these must support PoE Mode A (PoE over the data pair), many budget PoE injectors provide data over the unused data pair only. Care should be taken when selection a PoE device to power the GW2I / GW20 nodes. The GeNetix GS8 Gigabit PoE switch support PoE Mode A and Mode B and is ideal for powering all GeNetix Nodes.

GeNetix Switches

GS5IP

The GeNetix Switch 5IP or GS5IP is a five port IP65-rated unmanaged Gigabit network switch that can be powered via either mains power into its PowerCon True1 Mains Input connector or through PoE. The onboard Port Status LED's provide users a visual indication to the current active state of the ports as well as showing if the switch is running at Gigabit speed.

The GS5IP will not unlock any MagicQ PC Systems.



The GS5IP is a unmanaged network switch. Any network data received into the DATA IN port will be duplicated and outputted through all 4 ports. ChamSys Hardware and Software is not required to use this product.

GeNetix GS5IP Network Switch

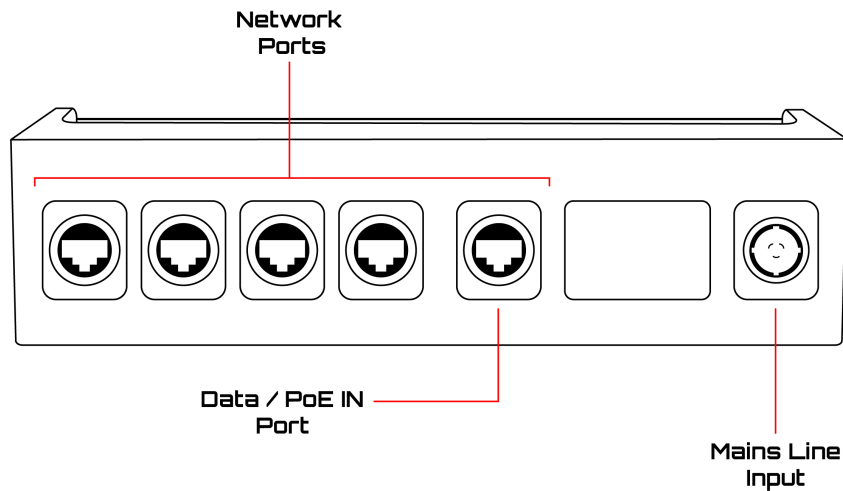

GS8

The GeNetix Switch 8 or GS8 is an eight port unmanaged Gigabit PoE network switch that provides a total output of up to 200W of Power over Ethernet across its eight ports. Ports 1 through 4 support IEEE 802.3bt up to 100W per port. In modes A & B, all ports 802.3af and 802.3at standards. The GS8 can be powered via the PowerCon True1 Mains input connector on the rear of the GS8.

The GS8 will not unlock any MagicQ PC Systems.



The GS8 is a unmanaged network switch. Any network data received will be duplicated and outputted through all ports

GeNetix GS8 Network Switch

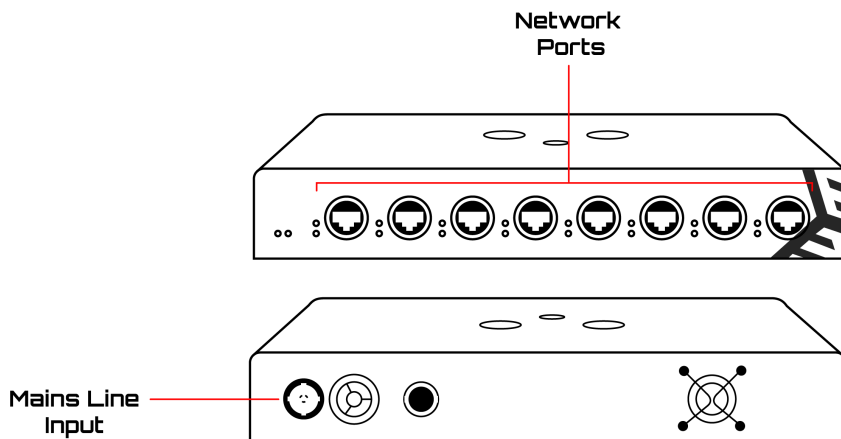

GeNetix DMX Splitters

GD4IP

The GD4IP is a compact 4-port IP65-rated DMX Splitter that features a single DMX Input to 4 DMX outputs, alongside this is a RDM Disable button allowing users to strip out RDM data and retime the DMX signal. The onboard Port Status LED's provide users a visual indication to the active state of the ports.

The GD4IP can be powered via mains power into its PowerCon True1 Mains input connector.



Any DMX data the GD4IP receives through its "DMX IN" port is duplicated to all outputs. RDM data can be enabled or disabled using the "RDM disable" button. ChamSys hardware and software is not required to use this product.

GeNetix GD4IP Network Switch

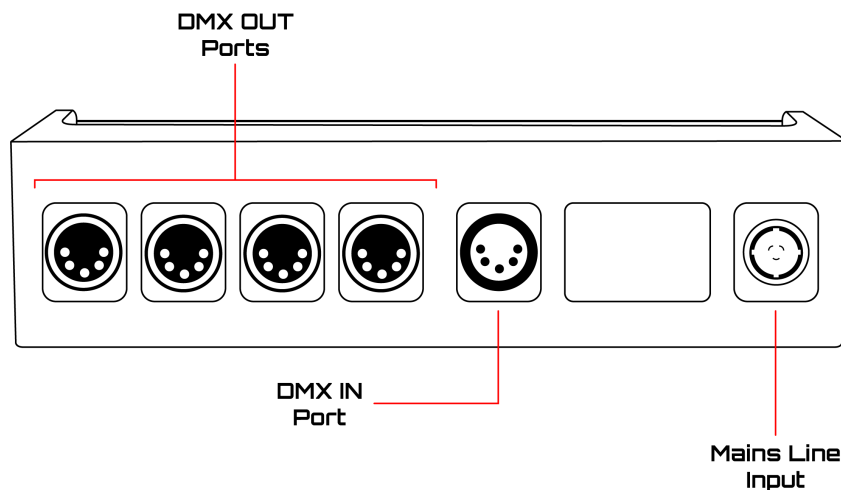

GeNetix 10Scene Interfaces

10Scene Store

The GeNetix 10Scene Store is a single universe wall or DIN Rail mounted stand-alone playback device that stores 10 static lighting Scenes (cues) which can recall stored scenes through connected 10Scene wall plates. Users can load Scenes from either QuickQ or MagicQ show files or program via its in-built DMX Input port.

The 10Scene Store is Powered by either PoE or external 48V power supply (not supplied). A suitable DIN Rail Mount Power supply example is the Powerld DG-60-548 which has been tested and proven with the GeNetix 10Scene Store. This simple installation device supports up to ten 10Scene wall plates, and features one DMX IN (XLR5 & Wago), one DMX OUT (Wago) and a network port.



The 10Scene Store can be configured via a MagicQ system or through the GeNetix Web Server.

GeNetix 10Scene Store

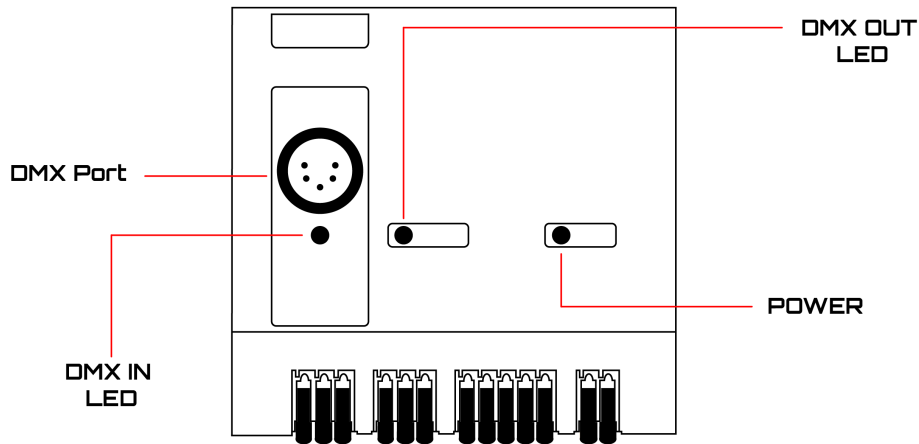

10Scene Gateway

The 10Scene Gateway is an interface allowing users to connect 10Scene Wall Plates to MagicQ/QuickQ systems. Converting from 10Scene to the ChamSys remote protocol, allowing 10Scene Wall Plates to integrate with MagicQ and QuickQ consoles.

2 10Scene ports allow users to connect up to 20 10Scene Wall Plates, providing a perfect solution for adding user friendly control to installations.

The 10Scene Gateway is powered via either via PoE or an external power supply.



GeNetix 10Scene Gateway

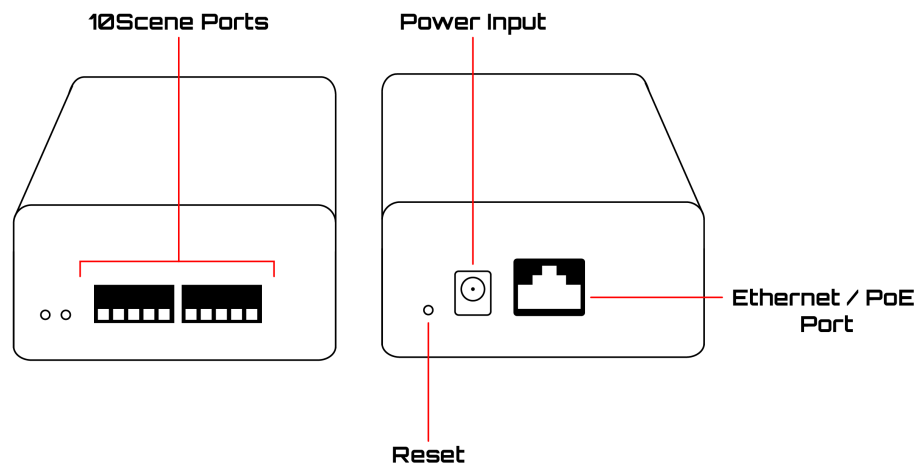

10Scene Wall Plates

The 10Scene Wall Plate features ten 10Scene trigger buttons, with dual colour LED status indication.

Users can connect 10Scene wall plates directly to the QuickQ Rack or to the SnakeSys Gateway interface, where it can then integrate with any MagicQ or QuickQ system for remote Scene activation.

GeNetix 10Scene Wallplate

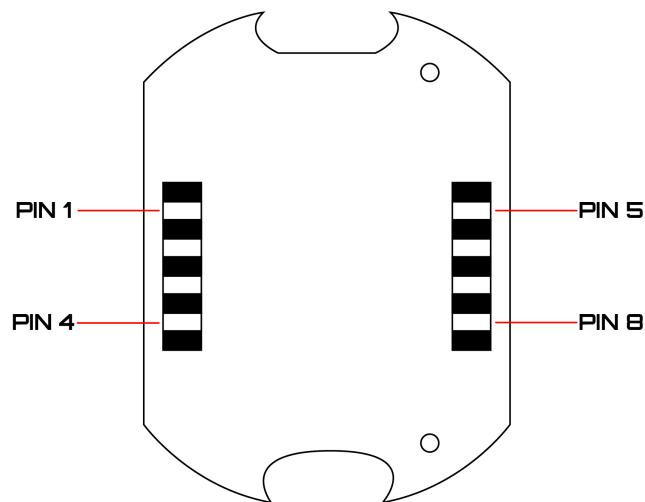

Chapter 3. Node Navigation

Node Encoders & Buttons

The GN2, GN5 and GN10 Nodes can be configured via their in-built display, via MagicQ/QuickQ consoles and their Web server. When configuring GeNetix devices via the in-built display, the node can be navigated in the following way:

Node Navigation

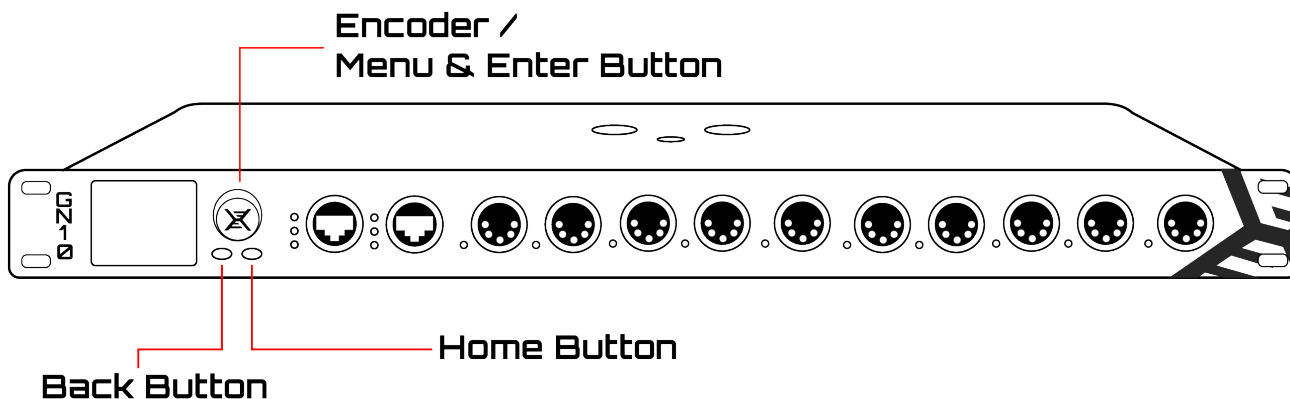

The Encoder is pressed to access the Node Menu, then used to scroll through menu option and pressed to select the menu item or confirm options. The Back button moves up a level from the current menu level. The Home button will return back to the Node Home Display no matter which menu option is currently on the display.

Node Home Display

The home display shows the status of the node, along with the device IP address, Name and Port configuration. On GN5 and GN10 nodes the home display will also display incoming Timecode and MIDI messages.

The Port configuration boxes change in their highlighted colour in line with Node Ports colours, see [Ports section](#) for details.

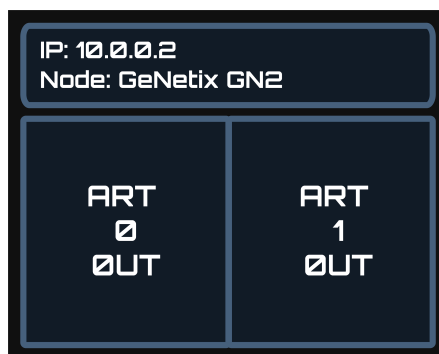

Menu Navigation

Pressing the encoder knob from the home display will enter the main menu. Main menu options are described in the preceding sections.

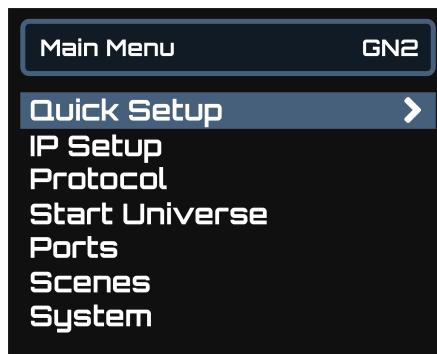

Chapter 4. Quick Setup

The Quick Setup menu contains a choice of 6 common preset Node configurations. These configurations are:

Table 1. QuickQ Setup Menu Options

Menu Option	Menu Action
Art-Net 0..1	Sets Node into Art-Net mode, sets Ports to sequential universes with Port 1 set to Art-Net Universe 0, Port 2 to Art-Net Universe 1 and so on.
Art-Net 1..2	Sets Node into Art-Net mode, sets Ports to sequential universes with Port 1 set to Art-Net Universe 1, Port 2 to Art-Net Universe 2 and so on.
Art-Net 0..0	Sets Node into Art-Net mode, sets all Ports to the same Art-Net Universe - Art-Net 0. All ports will output Art-Net Universe 0.
sACN 1..2	Sets Node into sACN mode, sets Ports to sequential universes with Port 1 set to sACN Universe 1, Port 2 to sACN Universe 2 and so on.
sACN 1..1	Sets Node into sACN mode, sets all Ports to the same sACN Universe - sACN 1. All ports will output sACN Universe 1.
Splitter	Option available on GN5 and GN10, in this mode device acts as a DMX Splitter. Sets port 1 to DMX Input, Ports 2 onwards output data received from Port 1. Art-Net / sACN input is ignored in this mode.



When using the GN5 / GN10 in Splitter mode RDM messages are not supported. RDM Messages are ignored / not passed through by the GN5 / GN10 when used in Splitter mode.



Chapter 5. IP Setup

The IP Setup menu has two options to set the node to a default 2. or 10. IP address. Both of these options will set the node Subnet mask to 255.0.0.0. The Custom IP address option allows a custom static IP address and Subnet Mask to be set by the user on the node.

Table 2. IP Setup Options

Menu Option	Menu Action
2.X.X.X	Sets Node to a unique 2.X.X.X IP address based on the devices mac-address with a /8 (255.0.0.0) Subnet
10.X.X.X	Sets Node to a unique 10.X.X.X IP address based on the devices mac-address with a /8 (255.0.0.0) Subnet
Custom IP Address	Allows the node to be given a user configurable IP address and Subnet

Chapter 6. Protocol

The Protocol Menu option is to quickly change the protocol setting for all ports of the Node.



Note that any custom protocol setting on individual ports is reset when recalling these options.

Table 3. Protocol Menu options

Menu Option	Menu Action
Art-Net OUT	Sets all Ports of the Node to Art-Net Output.
sACN OUT	Sets all Ports of the Node to sACN Output.
Art-Net IN	Sets all Ports of the Node to Art-Net Input.
sACN IN	Sets all Ports of the Node to sACN Input.



Chapter 7. Start Universe

The Start Universe menu option is used to set the node's Ports universe numbers sequentially starting from Port 1, the protocol menu option above defines the protocol used for the node's DMX ports. When setting the Start Universe, this also sets the Port universes for all ports of the node, with the ports universes increasing by 1 sequentially.



This setting overrides any manually set universe number configuration for ALL ports of the node and not just the first port of the node.

For example if the Node is set in Art-Net Mode and 'Start Universe' is set to 0, then Port 1 of the Node would be set to Art-Net 0 and Port 2 Art-Net 1 and so on. If 'Start Universe' is set to 10, then Port 1 would be set to Art-Net 10, Port 2 Art-Net 11, Port 3 Art-Net 12 and so on.

Chapter 8. Ports

Port Configuration

Allows for individual Ports of the Node to be configured separately.

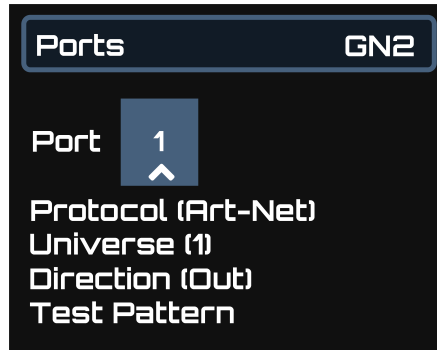

Port

The Port number relates to the physical DMX Port of the node.

Protocol

Protocol allows the selected port to be configured between Art-Net or sACN, there is also a 'none' option to disable port output.

Universe

Universe specifies the selected DMX Ports protocol universe number. For example is Port 1 has been select and Universe has been set to 10, the Port would output Universe 10 (either Art-Net or sACN, depending on the Protocol setting above).

Merge Mode

DMX merge mode determines the behaviour of the GeNetix Node when multiple sources of DMX are being input through a single port. Control of the connected fixtures can be adjusted between DMX sources depending on the Merge Mode set.

The configurable merge modes include:

- HTP - The highest data value received per channel will take control within the specified universe.
- LTP - The latest data value received per channel will take control within the specified universe.
- Highest IP - The data source with the highest IP address will control the output of the universe/port as a whole.
- Lowest IP - The data source with the lowest IP address will control the output of the universe/port as a whole.

Direction

Direction is used to set the selected DMX Ports mode from either DMX Output, DMX Input or DMX Fallback

Test Pattern

Test pattern will output a 'ramp' on all DMX channels of the selected Port from 0 to 255. As soon as this menu is exited the ramp on the port will stop. The test pattern automatically turns off after 60 seconds. The port LED shows purple whilst the test pattern is in operation.



Care should be taken using test patterns if any pyrotechnic or special FX devices are located on the DMX universe.

DMX Fallback

DMX Fallback enables fixtures on a single universe to be connected in a loop to two ports on the GeNetix node for redundancy. If a single cable is broken anywhere in the DMX loop, all fixtures can still receive DMX.

Each port can be set to Output, Input or Fallback.

When a port is set to Fallback it is by default operating as Input.

The node periodically checks for DMX being received in on the Fallback port, if after a timeout of at least 2 seconds there is no input detected then it changes into Output mode, outputting the Art-Net or sACN universe configured.

When operating as an output, it periodically briefly changes to an input to sense whether DMX data is now being received. If detected, the port stays as an input continuing periodic checking of the incoming DMX.

Different LED states are used to indicate if Fallback is configured, and in operation.

When using Fallback it is normal to set both the main output port and the Fallback port to decode the same Art-Net / sACN universe.

DMX Fallback is supported within a GeNetix node and also between multiple GeNetix nodes. For example, an installation could have a primary GN10 and a backup GN10 that provides both backup (in case the node fails) and DMX Fallback (in case of cable failure/fixture failure).

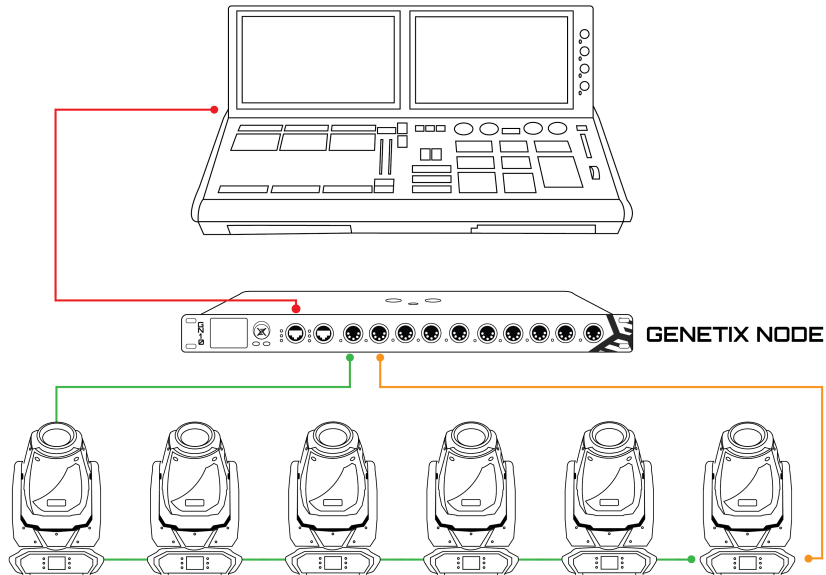

DMX Merging

DMX Merging enables fixtures on a single universe to be connected to multiple sources of DMX data.

Merging is enabled when two or more sources of DMX are input to a specific universe and a merging mode option is set on the port.

When more than one source is detected on a single universe, the corresponding port LED will change to a solid red colour.

HTP Merge

The highest data value received per DMX channel will take priority and be output to the DMX port.

LTP Merge

The latest data value received per DMX channel will take priority and be output to the DMX port.

Highest IP Address Priority

The data source with the highest IP address will take control of the universe / port as a whole.

Lowest IP Address Priority

The data source with the lowest IP address will take control of the universe / port as a whole.

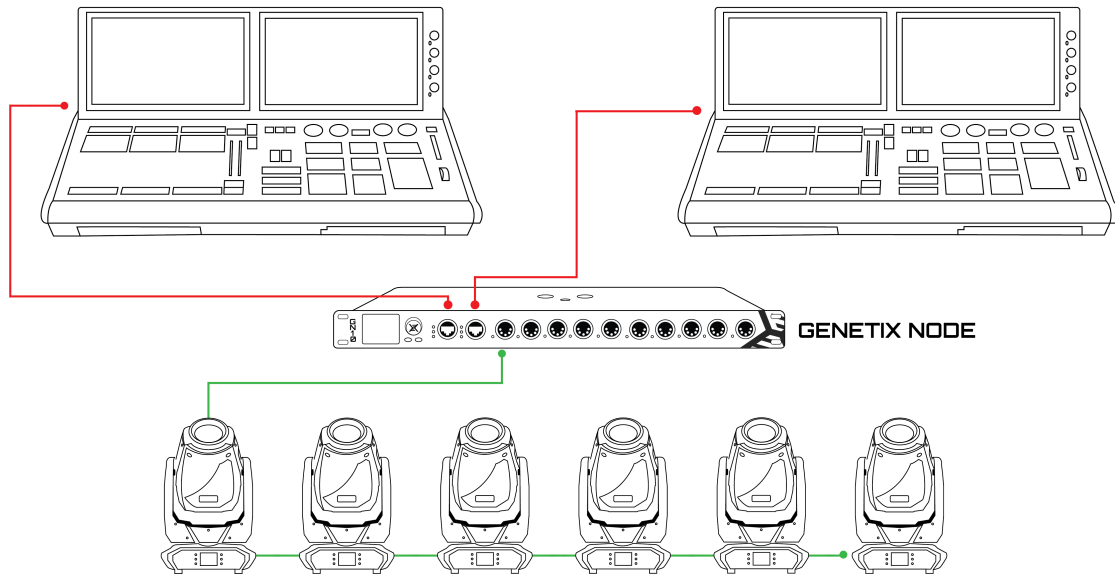

DMX Port LEDs

On the GN2, GN5, GN10, GW2I and GW2O the following LED colours are used:

Port set to output:

LED Colour	Description
Dark Blue	Receiving good Art-Net/sACN data for this port (no Scene Active)
Red	Receiving good Art-Net/sACN data for this port from 2 or more sources (no Scene Active)
Cyan	Receiving good Art-Net/sACN data for this port (but Scene Active)
Green	No Art-Net/sACN being received for this port (but Scene Active)
Flashing Red	Test pattern being output
Off	No Art-Net/sACN being received for this port

Port set to Fallback:

LED Colour	Description
Yellow	DMX loop input being received
Purple	No DMX input - fallback in operation
Off	No Art-Net/sACN being received for this port

Port set to input:

LED Colour	Description
------------	-------------

White	DMX input being received
Off	No DMX input

Note that during Identify all LEDs will be blue.



Chapter 9. Scenes

GeNetix nodes support storage of 10 Scenes that can be recorded from the incoming Art-Net or sACN data. Scenes contain DMX data for one or more ports on the node. Scenes are recorded as static lighting states, they do not contain FX or other complex programming.

Recording of scenes can be initiated from the front panel of the Node, from MagicQ / QuickQ consoles and also via the Web server.

Each Scene can have a name and a fade time set.

Scenes can be replayed from the front panel of the Node, from MagicQ/QuickQ consoles or via the Web server. When a Scene is active the front panel display will show the Scene name and the DMX port LEDs will be cyan or green depending on whether incoming Art-Net / sACN data is still present.

Crossfading of scenes is performed on all channels - the use of fade times is therefore best when changing intensity and colours rather than on stepped attributes such as gobo wheels.

The complete set of Scenes can be managed from MagicQ, enabling easy control and modification of installations. The Scenes can be retrieved from the node to MagicQ - loaded into either the first 10 Playbacks or 10 items in an Execute Window. The Scenes can be stored back into the node from MagicQ from the Playbacks or Executes.

Scenes can be triggered from 10Scene Wall Plates when the 10Scene Wall Plate mode is set to Scenes or Only Scenes.

When set to Only Scenes, then one of the Scenes is active at all times - this is useful for simple installations without consoles.

When set to Scenes, Scenes are triggered from the 10Scene Wall Plate, but if all 10Scene buttons are off then no Scenes are active and the node operates normally passing through network data to DMX.

Configuring Scenes

Scenes can be recorded on the GeNetix node by pressing the STORE SCENE soft button from within MagicQ or via the Node Menu and selecting the Scene to store to from the choices in the dialog box. Alternatively from MagicQ press the RECORD button and select a Scene in the window. The GeNetix node stores the current state of its network data for all ports that are set as Outputs.

From MagicQ Scenes can be removed by SHIFT and the REMOVE SCENE soft button and selecting the Scene to remove. Only programmed Scenes will be shown in the dialog box. Alternatively press the REMOVE button and select a Scene in the window. The Scene is removed for all ports on the GeNetix node. The Scenes can be retrieved from the node to MagicQ by pressing the RETRIEVE SCENES soft button and choosing the option of either the first 10 Playbacks or 10 items in an Execute Window. Playbacks and Execute Items will only be generated for the Scenes that are present on the node. If no Scenes are programmed then no Playbacks / Execute Items will be created.

MagicQ will only retrieve values for patched channels on the console universes corresponding to the ports on the GeNetix node. If MagicQ has no heads patched then MagicQ will patch generic dimmers on all the console universes corresponding to the ports on the GeNetix node prior to retrieving the Scene.

This enables retrieving of Scene data even when the patch has been lost. The Scenes can be sent back to the node from MagicQ by pressing the SEND SCENES soft button and choosing from Playbacks or Executes. If the Playback or Execute Item is not present then no Scene will be created. MagicQ will send value 0 for any channels that are not patched.

Controlling Scenes

Scenes can be controlled from 10Scene Wall Plates when the 10Scene mode on the GeNetix is set to Scenes or Only Scenes.

When set to Only Scenes, then one of the Scenes is active at all times – this is useful for simple installations without consoles.

When set to Scenes, then Scenes are controlled from the 10Scene Wall Plate, but if all 10Scene buttons are off then no Scenes are active and the node operates normally passing through network data to DMX.

Chapter 10. System

Lost Data Input

How a node reacts when losing network data (Art-Net or sACN) can be configured:

The network is only considered to be lost when data for all network ports configured as Outputs is lost.

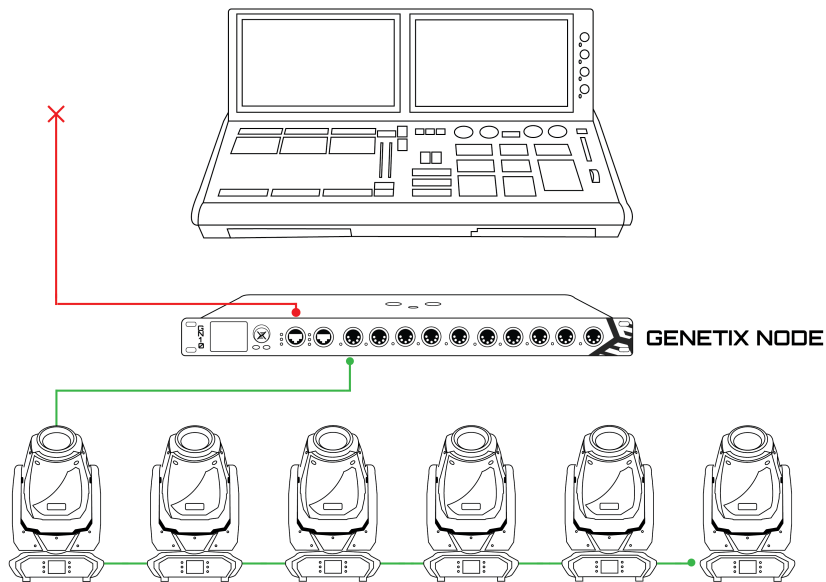

Table 4. Lost Data Input

Menu Option	Menu Action
Hold (default)	Holds the last output DMX values
Zeroes	Outputs DMX 0s on all channels
None	Stops outputting DMX
Scene	Outputs the contents of a Scene. If the Scene is not programmed for one or more ports then those port hold the DMX
Scenes Panel	Outputs the contents of a Scene selected from a 10Scene Wall Plate. If the Scene is not programmed for one or more ports then those ports hold their previous DMX.

Sync Mode

GeNetix nodes support synchronised DMX output to reduce tearing. Synchronisation is controlled via ChamNet and is available when used with MagicQ consoles.

GeNetix nodes also support Art-Net and sACN synchronisation.

Table 5. Sync Mode

Menu Option	Menu Action
None	Sync Disabled
Multi Unit	...
Auto Detect (default)	...

RDM

GeNetix network nodes support ANSI E1.20 RDM.

The GeNetix nodes only perform RDM operations when requested by a console or controller. They do not perform discovery on start up, or at predefined intervals. GeNetix Nodes only perform RDM discovery when explicitly requested by the console. This ensures that show critical DMX operation is not affected by RDM

Options are:

Table 6. RDM

Menu Option	Menu Action
RDM Enabled (default)	Enables RDM (Remote Device Management) on all Ports of the Node
RDM Read Only	Allows the connected fixtures RDM data to be read by Lighting Consoles, but will not pass any RDM modify commands from controller to fixtures. This is particularly useful in fixed installations where venue staff may want to block fixtures DMX address and mode from being modified
RDM Disabled	Disables RDM on all ports of the Node

DMX Timings

Table 7. DMX Timings

Menu Option	Menu Action
DMX Frame	DMX Frame timing, range from 49 to 149us (default 56us)
DMX MAB	Mark after break timing, range from 12 to 99us (default 12us)
DMX Break	DMX Break timing, range from 92 to 9999us (default 176us)

Lock

GeNetix nodes support a lock PIN to prevent the configuration being modified from the front panel of the GeNetix and also optionally from all network interfaces. The PIN applies to each interface separately and each instance of MagicQ, QuickQ or web server.

When the lock PIN is active the PIN must be entered to use the menu system. The system can be relocked from the menu. When unlocked, after 30 seconds of inactivity the device automatically locks

again.

When set to "All Interfaces" the PIN also restricts access from MagicQ and QuickQ consoles and from the web server.

Users that forget their passwords will need to contact ChamSys support to get a recovery code. Each device has a unique recovery code.

Table 8. PIN

Menu Option	Menu Action
Unlock (default)	Node fully unlocked and configurable
Lock Device Only	Locks the devices in built display and buttons requiring PIN entry to unlock, device can be configured via the web server and console without need for PIN
Lock All Interfaces	Locks device, Web server and configuration from Console requiring PIN entry to unlock
Set Pin	Available when device is unlocked allowing customer device PIN to be set

Node Name

Allows a custom name to be given to the device. The Node Name is displayed on the home screen of the Node and also displayed in the web server and on MagicQ/QuickQ consoles. This is particularly useful when multiple nodes are present on the network to allow for Node Identification.

Factory Reset

This setting will reset the device back to it's original out of box configuration. All user data is erased after a Factory Reset, this includes all node settings including IP address, Port & Protocol settings, Scenes and User Configs.

Chapter 11. User Configs

All nodes support the saving and recalling of configuration data as User Configs. Configs can also be triggered from 10Scene Wall Plates when the 10Scene Wall Plate mode is set to Configs. This is particularly useful for live environments for example at a festival, where a Wall Plate could be used to recall Configs changing the node Art-Net/sACN universes for quick change overs between controllers of the rig.

GeNetix nodes support 10 custom User Configs. Configs store the following Node configuration settings:

Table 9. Configs

Setting	Stored in Configs
Node IP address and Subnet	Yes
Ports Settings - Protocol, Universe, Direction	Yes
MIDI Settings	Yes
Timecode Settings	Yes
RDM Settings	Yes
DMX Timings	Yes
Lost Data Input Settings	Yes
10Scene Settings	Yes

Loading Configs does not change the contents of Scenes, Scene data is common for all Configs. Configs can be Saved, Loaded, Reset and Re-named via the Node Display, web server or from MagicQ consoles.

Chapter 12. 10Scene

The GN5 and GN10 10Scene port can be used in the following configurations:

- None
- Scenes (Default)
- Only Scenes
- User Configs
- Gateway

When set to Scenes it control the Scenes. When no 10Scene buttons are active then no Scenes are active and the GeNetix node operates normally with DMX control from a console.

When set to Only Scenes it operates like a 10Scene Store - One Scene must always be active and DMX control from a console is not supported. This is designed for installs where there is no console.

When set to User Configs, pressing the 10Scene button loads configuration 1 to 10 depending on the button pressed.

When set to Gateway the 10Scene of the Node (GN5 or GN10 only) functions like a 10Scene Gateway. From MagicQ/QuickQ it is interchangeable with a 10Scene Gateway.

This setting also controls the behaviour of 10Scene external triggers, so it is visible on all GeNetix nodes regardless of whether they have a physical 10Scene port.

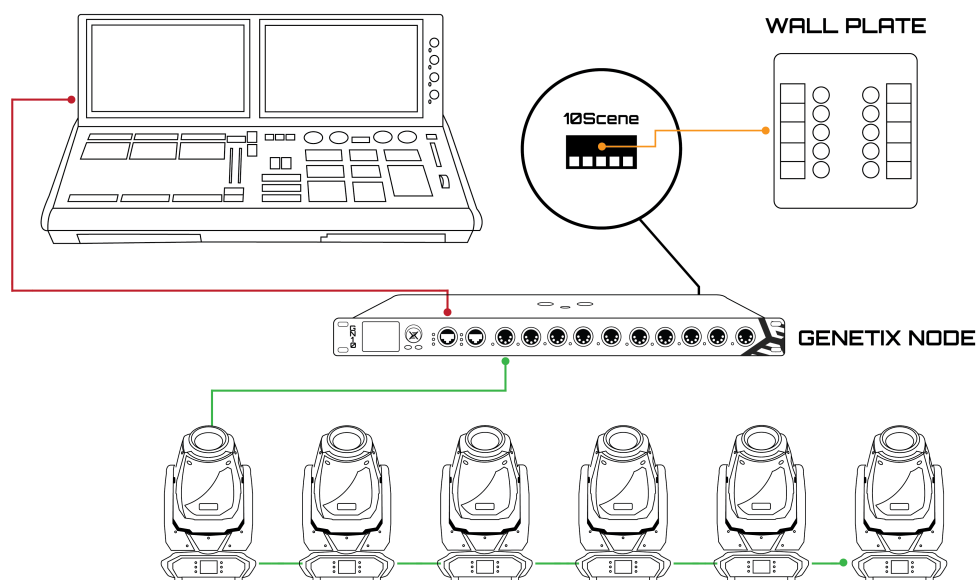

10Scene External Control

The Scenes on the GeNetix nodes can be controlled via external protocols. The options are

- None
- 10Scene App

- MIDI notes 0..9
- ChamSys Remote Ethernet Protocol (CREP)

GeNetix only supports one Zone ID. The Zone ID supported is determined by the ChamNet ID of the GeNetix device. By default the ChamNet ID is 0 (Def) and the GeNetix will respond to 10Scene Zone 1. When the ChamNet ID is non zero then the Zone ID is the ChamNet ID.

The 10Scene App shows the names and state of the 10Scenes programmed in the GeNetix and enables Scenes to be selected. When the GeNetix node Lock Mode is set to Lock All Devices, then the PIN number of the GeNetix must be entered on the 10Scene App.

MIDI is only available on GN5 and GN10. To control a Scene send MIDI Note On for notes 0 to 9 with velocity greater than 0.

GeNetix supports the X command from ChamSys Remote Ethernet Protocol. GeNetix supports CREP with or without a header on UDP port 6553. GeNetix accepts both x and X.

Command	Function
<button id> X	10Scene zone 1 button
<button id> , <state> X	10Scene zone 1 button with state
<zone id> , <button id> , <state> X	10Scene zone button with state

The 10Scene mode determines the action taken. Note that when the 10Scene mode is set to Gateway, then controlling of Scenes from the 10Scene App is not possible.

If state is not specified, then a button press and release is processed. Where state is specified, then it has the following functions:

State	Function
0	Button release (this causes the Scene changes)
1	Button press
2	Activate Scene
3	Release Scene (not supported if 10Scene mode is set to Only Scenes)

For example to activate Scene 2 send 2X.



Chapter 13. Contact Triggers

The GN5 and GN10 support a Contact Trigger input, this is wired to 2 pins on the 10Scene Port on the devices.

Trigger Mode

The trigger mode determines whether the trigger input is activated on close or open of the circuit, and whether it persists when the circuit is reopened / closed.

The options are:

Table 10. Trigger Modes

Trigger Option	Function
Active while open	The trigger activates when the circuit is opened, and released when the circuit is closed.
Active while closed	The trigger activates when the circuit is closed, and released when the circuit is opened.
Persistent on open	The trigger activates when the circuit is opened and remains active.
Persistent on close	The trigger activates when the circuit is closed and remains active.

Trigger Scene

The GN2, GN10 and 10Scene Store support a trigger input on the 10Scene port.

The trigger input can be set to activate one of the ten Scenes when the trigger occurs.

Chapter 14. MIDI & Timecode

The GN5 and GN10 support MIDI & LTC timecode input and output.

Timecode

The GN5 and GN10 support MIDI & LTC timecode in and out and can send and receive timecode over network via Art-Net timecode or ChamNet.

Timecode In

Timecode can be input as LTC through the 3pin female XLR LTC In connector or via MIDI via the 5 pin DIN MIDI connector. The GeNetix node can be configured to forward the timecode: as Art-Net timecode, as ChamNet timecode to a MagicQ or QuickQ console, or through one GeNetix to another.

The GeNetix node can be set to broadcast the timecode or to send it to a specific IP address. MagicQ consoles can be set to receive Art-Net or ChamNet timecode.

Timecode received on the LTC In or MIDI In ports is automatically retransmitted on the LTC Out and/or MIDI Out ports depending on the Timecode Out setting.

Timecode Out

The GeNetix node can be set to receive Art-Net or ChamNet timecode and forward it over the LTC Output and MIDI Output ports.

The Timecode Out setting determines which ports are used:

- None
- LTC
- MIDI
- LTC + MIDI

MIDI

The GN5 and GN10 support MIDI notes, MIDI CC, MIDI beat clock and MIDI system exclusive messages.

MIDI In

MIDI notes, beat clock and SysEx messages received via the MIDI In port can be forwarded over ChamNet to MagicQ and QuickQ consoles or from one GeNetix to another. There is no support for sending MIDI messages to 3rd party consoles over network.

MIDI can be sent to a MagicQ or QuickQ console on a specific IP address via the MIDI in transmit host IP option. If set to 0, then the GeNetix node broadcasts the MIDI messages.

MIDI notes, beat clock and SysEx messages received on the MIDI In port are automatically forwarded out the MIDI out port as received.

MIDI Out

MIDI notes, beat clock and SysEx messages received from a MagicQ or QuickQ console over ChamNet will be output from the MIDI Out port.

To send MIDI notes and SysEx messages out of MagicQ, set the MIDI out type in Setup, View Settings, MIDI/Timecode to "ChamNet Any Chan" or "ChamNet Req Chan". MagicQ then outputs any MIDI notes and SysEx messages from the Cue Stack N Macro to ChamNet and any direct MIDI out port.

Quick Setup of LTC/MIDI Timecode

Proper LTC/MIDI Timecode is reliant on the setting of certain options in the GeNetix Node, following the below steps will ensure the successful connection between the GN5/GN10 and a users lighting controller.

1. Connect LTC/MIDI generation device to the corresponding port on the back of the GeNetix Node.
2. Navigate from the GN5 node main menu to Timecode > IN > Mode and select Art-Net or ChamNet depending on requirements.
3. Ensure a network cable is connected between the GN5/GN10 and PC/Mac running MagicQ and that both products are in the same IP range.
4. In MagicQ navigate to Setup > View Settings > MIDI Timecode and set Timecode Decode to match the Timecode IN mode selected in step 2.
5. Begin LTC/MIDI generation

Chapter 15. MagicQ Configuration

All GeNetix node products can be configured from MagicQ PC & console systems.

When connected via USB, nodes act like a ChamSys USB to DMX interface. All configuration of DMX ins and outs can be controlled from the DMX I/O window.

When connected via Ethernet, nodes can be fully configured from the Net Manager window (Setup > View DMX I/O > Net Manager).

Inside of the Net Manager window are the below configuration options. The window is split into 4 tab views.

Devices View

The devices view displays an overview of all connected ChamNet network nodes. From the devices window each node's full configuration can be modified.

The following options are available in the Devices tab view:

ID

The ID field refers to the numerical order of devices connected to a users MagicQ system, alongside this the ID field allows users to set the ID for received ChamNet timecode.

Name

The name field displays the user configurable name for the GeNetix node. The default name for a GeNetix Node is based on the Node used, the GN5 for example has the default name "GeNetix GN5".

Status

The Status field displays whether the Node is detected by MagicQ, If experiencing issues with a GeNetix Node users are encouraged to check that the status field reads "Detected" when connected over network and "Detected (USB)", If not shown it is advisable to check the cable connection between a user MagicQ system and the GeNetix Node.

Type

The Type field display the type of GeNetix Node connected to the MagicQ system these types include:

- GN2
- GN5
- GN10
- GW2I/O
- 10Scene Store

Config

The Config field refers to the current configuration of the ports on a users GeNetix Node these configuration options include;

- Custom -Shown when custom options are set on the Ports.
- sACN Out - GeNetix Node ports will output sACN starting from sACN Universe 1
- Art-Net Out - GeNetix Node ports will output Art-Net starting from Art-Net Universe 0
- sACN In - GeNetix Node ports will input sACN starting from sACN Universe 1
- Art-Net In - GeNetix Node ports will input Art-Net starting from Art-Net Universe 0
- Art-Net Out Same Uni - All GeNetix Node ports will output Art-Net from Art-Net Universe 0
- sACN Out Same Uni - All GeNetix Node ports will output sACN from sACN Universe 1
- Match Console Outputs - GeNetix Node ports will match the output configuration of the first 2/5/10 universes in MagicQ

Uni

The Uni field allows users to set the start universe on the GeNetix Node, ports will increase sequentially from the number set here.

IP Address

The IP Address field displays and allows users to change the IP address currently attributed to the GeNetix Node.

Subnet Mask

The Subnet Mask field displays the currently set subnet mask. The subnet mask distinguishes the network address and the host address within an IP address.

MAC Address

The MAC Address field displays the Unique Mac Address for the connected GeNetix Device.

Firmware

The firmware field displays the currently installed firmware version on the GeNetix Node, this field will also show the latest available firmware version for the GeNetix Node.

Up Time

The Up Time field displays the total time elapsed since the GeNetix Node was initially connected.

Sync

The Sync field refers to the GeNetix Nodes ability to synchronise DMX output to reduce tearing. Synchronisation is controlled via ChamNet and is available when used in conjunction with MagicQ

consoles.

LED

The LED field allows users to set how the LED on a GeNetix Node act, the options include:

- Normal - LED's light when DMX is being Inputted or Outputted through a port.
- Off - LED's will stay off.
- Locate - All LED's will light up, this is usually used to identify a single node in a larger setup.
- Reserved

Active Scene

The Active Scene field allows users to select a scene stored on the GeNetix Node to output.

Trigger Scene

The Trigger Scene Field allows users to select a scene stored on the GeNetix Node to Output when a contact trigger is pressed.



Trigger Scene is only available on the GN5 and GN10 Nodes.

Lost Data

The Lost Data field allows users to set the behaviour of the GeNetix Node for when DMX data is suddenly lost, the options include:

- Hold DMX Output - The GeNetix Node will continue to Output the last figure it had received.
- No DMX Output - The GeNetix Node will cease to output any DMX.
- Zero DMX Output - The GeNetix Node will continuously output DMX at Zero.
- Scene 1-10 - Scenes Stored on the GeNetix Node can be set to output when data is lost.
- Scenes Panel - After data is lost users can output one of the 10 stored scenes on the GeNetix device through a 10Scene Wall Plate.

RDM

The RDM field displays the options regarding RDM or Remote Data Management this functionality allows fixtures to communicate with consoles the options in this field are as follows:

- Enabled - GeNetix Nodes can request RDM discovery of fixtures and change them.
- Read Only - GeNetix Nodes can discover fixtures can not change them.
- Disabled - GeNetix Nodes can not perform RDM functions.

User Config

The User Config allows users to save and recall configuration data, a GeNetix Node is capable of



storing 10 custom User Configs.

Factory Reset

The Factory Reset field when selected allows users to reset the GeNetix Node to its original out of box settings.



All user data including node settings, IP Addresses, Port & Protocol settings, Scenes and User Configs will be erased.

Lock

The Lock field allows users to enable a lock for the GeNetix Node and it's accompanying interfaces, the options available include:

- Device Only - Physical editing of the GeNetix Node will require a 4 digit pin code.
- All Interfaces - Physical editing of the GeNetix Node menu and control over web server will require a 4 digit pin code.

Timecode In

The Timecode In field allows users to select a configuration for the GeNetix node forward timecode: as Art-Net timecode, as ChamNet timecode to a MagicQ or QuickQ console, or through one GeNetix to another.

Timecode Host IP

The Timecode Host IP field allows users to configure how MIDI is sent to a MagicQ or QuickQ console on a specific IP address via the MIDI in transmit host IP option. If set to 0, then the GeNetix node broadcasts the MIDI messages.

Timecode Out

The Timecode out field allows users to configure how a GeNetix Node forwards Art-Net or ChamNet through the LTC or MIDI output ports on the rear of the GeNetix Node. The options available to users include:

- None - Timecode is not forwarded through any ports on the GeNetix Node.
- LTC - Timecode is forwarded through the LTC Port on the rear of the GeNetix Node.
- MIDI - Timecode is forwarded through the MIDI Port on the rear of the GeNetix Node.
- LTC & MIDI - Timecode can be simultaneously forwarded through both the LTC and MIDI ports on the GeNetix Node.



Timecode functionality is only available on the GN5 and the GN10.

MIDI In

The MIDI In field allows users to configure how MIDI notes, beat clock and SysEx messages are received via the MIDI In port. Options include ChamNet to MagicQ and QuickQ consoles or from one GeNetix Node to another.



There is no support for sending MIDI messages to 3rd party consoles over a network connection.

Upgrade Device

The Upgrade Device soft button allows users to update their GeNetix Devices over a network cable connection, the latest firmware upgrades available for GeNetix Devices will be bundled with the latest version of MagicQ.

Identify

The identify function can be toggled from the C encoder soft button inside of the Devices tab view.

When Identify mode is toggled on, all ChamNet devices' LEDs are set to off except for the selected device which is set into Identify mode. Stepping through the devices in MagicQ will Identify each device in turn.

When Identify mode is toggled off, all ChamNet devices return to their configured LED states.

GeNetix nodes with integrated screens indicate Identify mode by displaying an on-screen message in addition turning on all LEDs.

Ports View

The Ports tab within the Net Manager allows for more precise configuration of GeNetix Nodes ports, for users wishing to alter the input, output or protocol of individual ports of a GeNetix port.

Options View

The Options tab displays the options currently set on the GeNetix Node, different to the Devices tab the Options tab has options unavailable on the Device tab.

Set Pin

The Set Pin field allows users to set a 4 digit numerical code that is used to unlock the GeNetix Node when either the physical Node or interfaces are locked.

10Scene Mode

The 10Scene Mode field allows users to configure the behaviour of the 10Scene ports on the rear of the GN5 and GN10 options available to users include:

- Disabled - 10Scene functionality disabled



- Scenes Optional - Scenes are triggered from a 10Scene Wall Plate, but if all 10Scene buttons are off then no Scenes are active and the Node allows network data to DMX.
- Only Scenes - At least one Scene will always be active, this is useful for installations without a console.
- User Configs - Select user configurations for the GeNetix Node.
- Gateway - the GeNetix Node acts as gateway between a 10Scene Wall Plate and a lighting controller.

10Scene Ext

The 10Scene Ext field allows users to configure how 10Scene is controlled from external sources these options include:

- 10Scene App - Users can activate and deactivate 10Scene buttons through the 10Scene App that comes bundled with a MagicQ/QuickQ installation.
- MIDI Notes 0-9 - Users can toggle the activation of 10Scene buttons by sending MIDI notes ranging from 0; which will activate button 1 to 9 which will activate button 10.
- CREP - CREP refers to ChamSys Remote Ethernet Protocol which allows users to send custom UDP messages to their device to activate and deactivate 10Scene Buttons.

CREP Commands

Toggle 10Scene Button	<button id> X
10Scene Zone 1 Press or Release	<button id> , <state> X
10Scene Zone Press or Release	<zone id> , <button id> , <state> X

Button ID refers to

Scenes View

The Scenes tab allows users to view and configure the scenes currently stored inside the GeNetix Node, each GeNetix Node is capable of storing 10 separate scenes that can be swapped as desired.

Send Scenes

The Send Scenes soft button allows users to quickly export scenes from a MagicQ system to the GeNetix Node users can choose between sending the 10 playbacks on the current page of MagicQ or the first 10 items from execute page 1.

Retrieve Scenes

The Retrieve Scenes soft button allows users to quickly import scenes from the GeNetix Node into MagicQ.

Chapter 16. Web Server Configuration

The 10Scene Store and GeNetix nodes all contain an on-board web server allowing the node to be configured from a web browser.

The web configuration site can be accessed by navigating to the nodes IP address in the browser. The GeNetix product must be in the same IP address range as the connected browser device.



Only the 10Scene Store and GeNetix nodes have an on-board web server. GeNetix switch & splitter products are unmanaged.

Once connected, different configuration pages can be loaded by using the navigation menu on the left hand side of the page.

If viewed on a smaller device, this menu is automatically hidden and the "Hide/Show Menu" button can be pressed to view the menu.

Also shown within the page navigation is the current web server version and it's release date.

System Overview

The system overview page enables the current configuration of the connected node to be viewed at a glance.

The current name, serial number, IP address, subnet mask, firmware version, and bootloader version can be viewed in the top overview module.

The node can be reconfigured quickly by pressing the "Quick Setup" button and then selecting one of the [preset configurations](#).

Also shown on this page are each of the individual port settings currently applied on the node.

Each port has it's own overview module, displaying the: port number, direction, [status LED](#), port name, configuration type, and universe number.

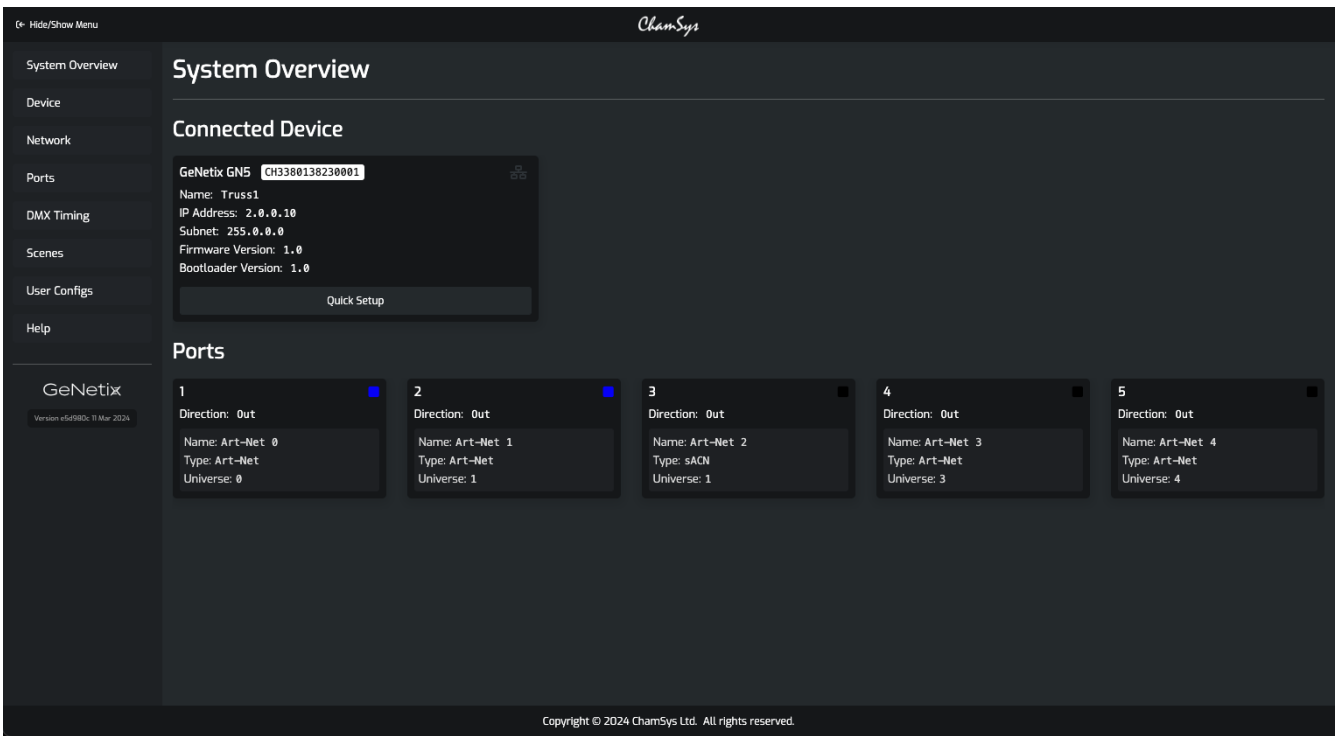

Figure 1. System Overview Page

Device

The device configuration page enables core system settings to be modified. Inside the configuration module, the node name, RDM setting and Lost Input Data settings can be changed.

Also found in the top module are additional options to identify and toggle the node LEDs. These can be found by pressing the 3 vertical dot icon in the top right of the module.

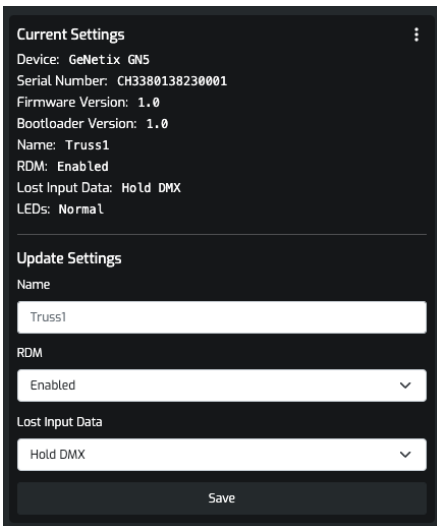

Figure 2. Device Configuration Module

Network

The network configuration page allows for both the IP address & subnet mask of the node to be modified.



Changing the node IP address or subnet mask to a value outside of the reachable network range may disconnect the GeNetix node from the connected device. The web server will additionally confirm this action if detected.

Current Settings
IP Address: 2.0.0.10
Subnet: 255.0.0.0

Update Settings
IP Address
2.0.0.10
Subnet Mask
255.0.0.0
Save

Figure 3. Network Configuration Module

Ports

The port configuration page allows for each of the node ports to be configured. Each port has its own configuration module and can be selected by clicking the circle select box to fine tune that ports settings.

Multiple ports can be configured at the same time by selecting the "Multi-Select Ports" option or by holding shift and then clicking on each port.

Once selected, the port's: direction (in/out), name, output/input type, and universe number can be modified. Once adjusted to the desired configuration, the selected ports settings can be saved by pressing the "Save" button.

At all times the current port settings are displayed at the top of the page.

To quickly configure all ports on the connected node, the "Quick Configure" wizard button can be pressed in the top right of the page. This opens a module whereby a direction, output/input type and start universe are entered. When the "Configure Ports" button is pressed, the node is reconfigured to the desired settings, sequentially numbering the ports from the [start universe](#) entered.



When using "Quick Configure", if sACN is selected along with a start universe of 0, the system will auto-adjust the start universe to 1. 0 is not a supported start universe for sACN but is supported for Art-Net.



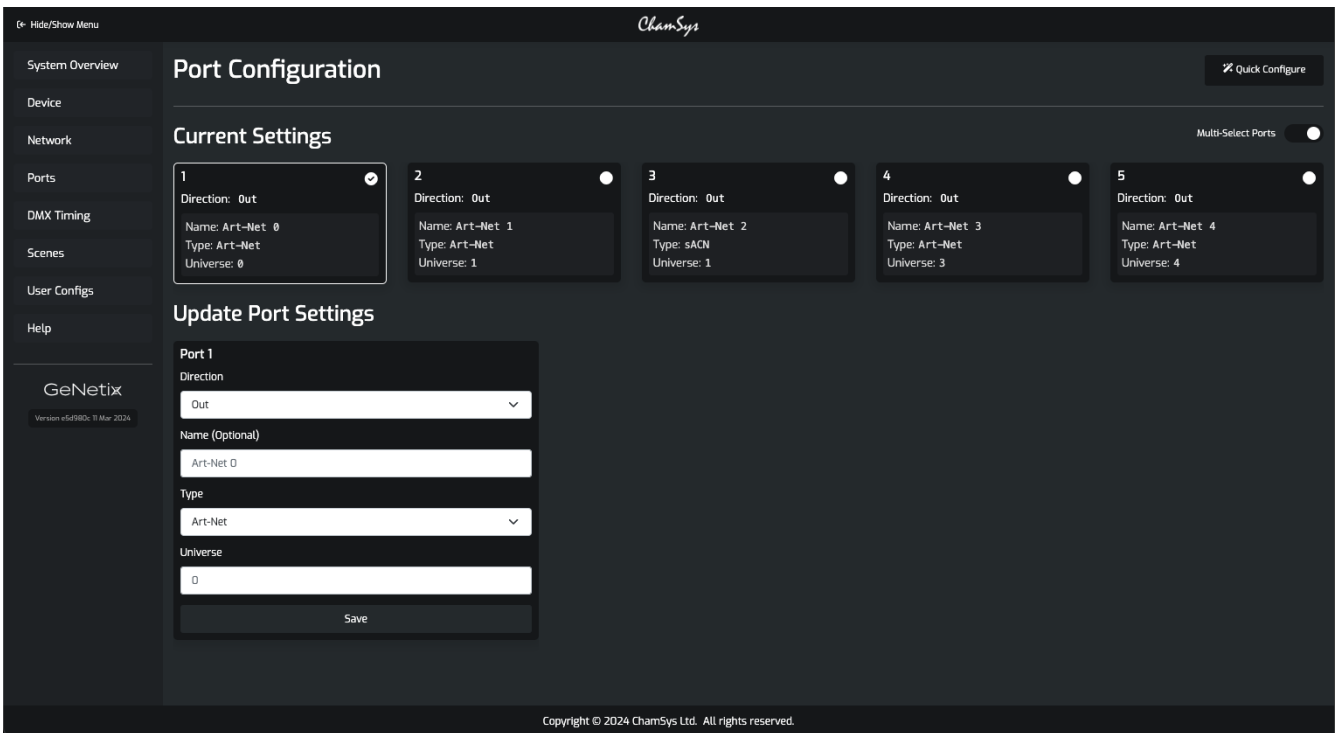

Figure 4. Port Configuration Page

DMX Timing

The DMX timing configuration page enables core timing values of the out-going DMX to be modified. Inside the configuration module, the separate: frame timing, MAB and break timing can be changed.

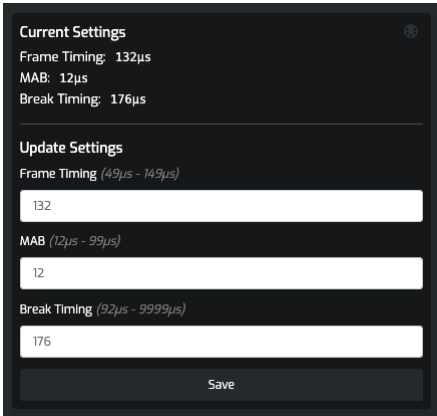

Figure 5. DMX Timing Configuration Module

Scenes

The scene configuration page allows for the on-board scenes to be recorded, erased, replaced, and basic settings modified.

At all times 10 slots are displayed on the page. If a slot is completely blank it is labelled "+ Add Scene", clicking the empty slot will record the current output of the node to that scene slot.

If a scene is recorded to that slot, the scene's name and fade timing are displayed.

In the top right of each scene slot are controls to play (green triangle icon), replace/record over (red circle icon), and erase (white trash icon) that particular scene. When a scene is active, "ACTIVE" is

displayed in the top left of that slot and the play icon is replaced with a stop (green square) icon.

To edit a recorded scene's name or fade time, new values can be entered into the respective boxes. Hitting the "Save" button will save that scene's new name and/or timing.

Supported on GeNetix GN5 & GeNetix GN10 nodes is the option for launching a scene when the 10Scene contact trigger pin is activated. On these products an additional module is shown at the bottom of the page allowing for this scene to be defined.

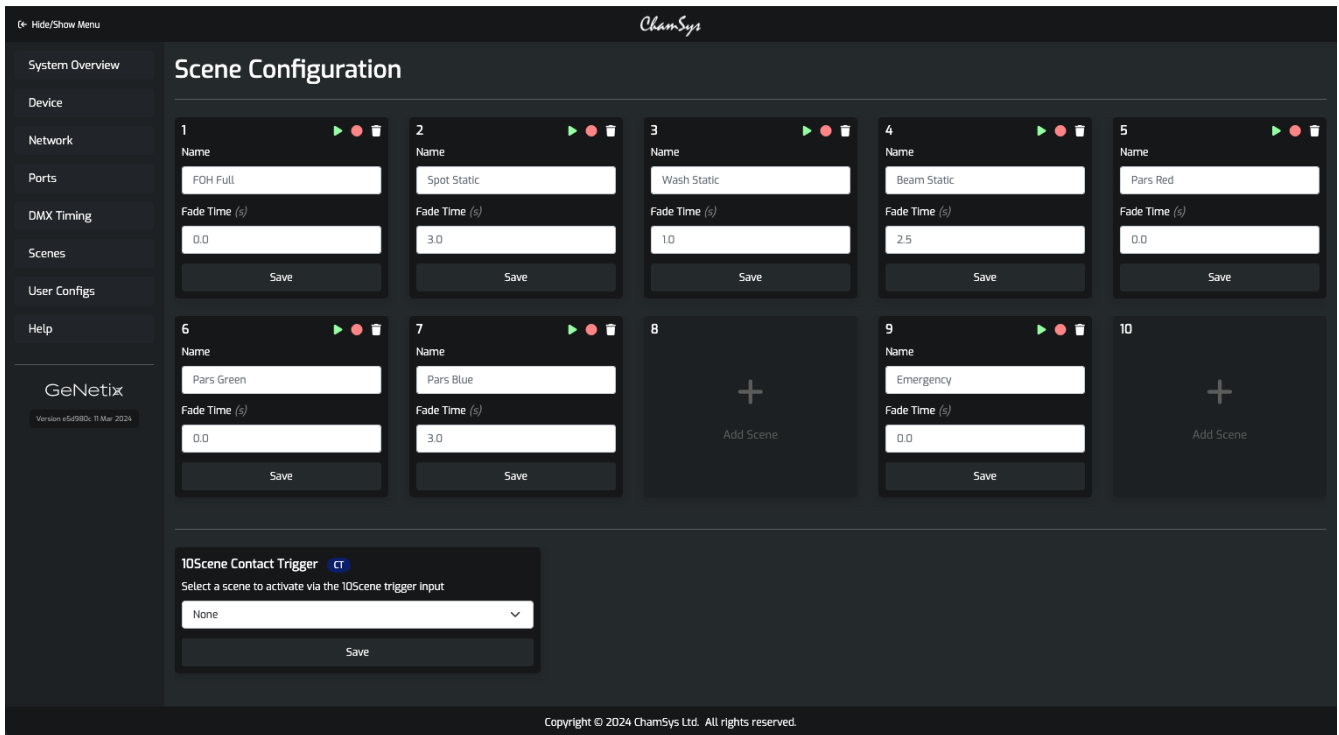

Figure 6. Scenes Configuration Page

User Configs

The User Configs page allows for custom user configurations to be saved, recalled or cleared. As described in the [User Configs](#) chapter, the node settings can be saved to 1 of 10 slots allowing for quick reconfiguring of the node to user favoured settings.

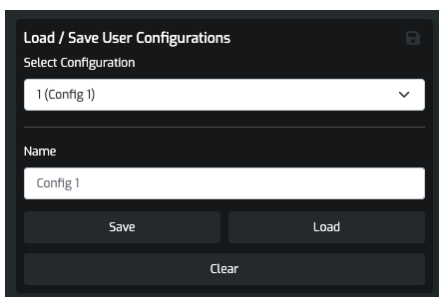

Figure 7. User Configs Module

Help

The help & support page details the most recent GeNetix documentation location along with warranty and support contact information.

At the very bottom of the page are some details of the node model number, serial number, firmware version, bootloader version and web server application version.

These details may be useful if contacting [ChamSys Support](#).

PIN Locking / Unlocking

When the GeNetix node is placed in a PIN locked state, the web configuration page can be unlocked by entering the correct 4-digit pin into the unlock module.

When entered correctly the web page will automatically refresh, enabling configuration from the web page.

If the PIN is entered incorrectly the page is locked for a few seconds, not allowing any further PIN attempts until the timer has expired. On further failed PIN attempts the lockout time is increased.

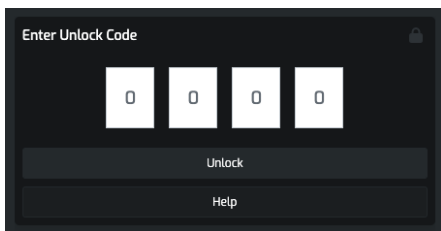

Figure 8. PIN Entry Module

Error Messages

When an error occurs the web configuration page will blank all controls and present one of the following error codes.

NOSERV	<p>The web page can no longer connect or the connection was refused to the GeNetix node. This can occur if the node is powered off but the web page is still loaded.</p> <p>Typically rebooting the node will reestablish an active connection.</p>
INVDATA	<p>The web page was able to establish a connection to the node but the data returned to the browser has failed the validation check.</p> <p>Please contact ChamSys Support if experiencing this error.</p>

Chapter 17. Feature Comparison

GeNetix Nodes Comparison

Table 11. GeNetix Nodes Comparison

Firmware Function	GW20	GW2I	GN2	GN5	GN10	10Scene Store
Connection to MagicQ via USB	N	N	Y	Y	Y	N
Connection to MagicQ via Network	Y	Y	Y	Y	Y	Y
DMX512 in and out	Y	Y	Y	Y	Y	Y
Configurable DMX Timings	Y	Y	Y	Y	Y	Y
Art-Net	Y	Y	Y	Y	Y	Y
sACN	Y	Y	Y	Y	Y	Y
ANSI E1.20 RDM	Y	Y	Y	Y	Y	N
DMX Fallback	Y	Y	Y	Y	Y	N
DMX Synchronisation	Y	Y	Y	Y	Y	N
Node Identify	Y	Y	Y	Y	Y	N
Scenes	Y	Y	Y	Y	Y	Y
Recall Scenes with fade times	Y	Y	Y	Y	Y	Y
Front panel display	N	N	Y	Y	Y	N
ChamNet Support	Y	Y	Y	Y	Y	Y
Configurable from Art-Net	Y	Y	Y	Y	Y	Y
Web server	Y	Y	Y	Y	Y	Y
Factory Reset	Y	Y	Y	Y	Y	Y
Factory Presets	Y	Y	Y	Y	Y	Y
Firmware update	Y	Y	Y	Y	Y	Y
Saving and recalling User presets	Y	Y	Y	Y	Y	Y
Lock / unlock node	Y	Y	Y	Y	Y	Y
LTC and MIDI Timecode to/from Art-Net/ChamNet	N	N	N	Y	Y	N

Firmware Function	GW20	GW21	GN2	GN5	GN10	10Scene Store
MIDI notes to/from MagicQ/QuickQ via ChamNet	N	N	N	Y	Y	N
Trigger of Scenes from 10Scene Wall Plates	N	N	N	Y	Y	Y
Trigger Presets from 10Scene	N	N	N	Y	Y	Y
10Scene Gateway functionality	N	N	N	Y	Y	N
Unlock of MagicQ PC Demo Mode	N	N	Core Mode	Full Unlock	Full Unlock	N

GeNetix Switches Comparison

Table 12. GeNetix Switches Comparison

Firmware Function	GS5IP	GS8
Gigabit Network Speed	Y	Y
Unmanaged Switch	Y	Y
IP65 Rated	Y	N
Rack Mountable	N	Y - 1U height
Truss Mountable	Y	Y
Can be powered via PoE	Y	N
PoE Output from Switch	N	Y - Supports PoE++ (ports 1-4), PoE+ (ports 5-8). Total 200w output
Unlock of MagicQ PC Demo Mode	N	N

Chapter 18. 3rd Party Console Support

GeNetix products are compatible with 3rd party / other manufacturer consoles. GeNetix Nodes support industry standard protocols such as Art-Net and sACN and are fully compatible with 3rd party consoles and software supporting these protocols when used as an Ethernet-DMX node.

There are some features of GeNetix Nodes which use ChamSys ChamNet protocol, which are not compatible with 3rd party consoles such as sending of MIDI notes over Network.

3rd Party Consoles Support with GeNetix Nodes

Table 13. 3rd Party Consoles GeNetix Nodes Compatibility

Firmware Function	GW20	GW2I	GN2	GN5	GN10
Connection to 3rd Party Consoles via USB	N	N	N	N	N
Connection to 3rd Party Consoles via Network	Y	Y	Y	Y	Y
DMX512 in and out	Y	Y	Y	Y	Y
Configurable DMX Timings	Y - via Web server only	Y - via Web server only	Y - via Web server/Node display	Y - via Web server/Node display	Y - via Web server/Node display
Art-Net	Y	Y	Y	Y	Y
sACN	Y	Y	Y	Y	Y
ANSI E1.20 RDM	Y	Y	Y	Y	Y
DMX Fallback	Y	Y	Y	Y	Y
DMX Synchronisation	N	N	N	N	N
Node Identify	N	N	N	N	N
Scene Storage	Y - via Web server only	Y - via Web server only	Y - via Web server only	Y - via Web server only	Y - via Web server only
Recall Scenes with fade times	Y - via Web server only	Y - via Web server only	Y - via Web server/Node display	Y - via Web server/Node display	Y - via Web server/Node display
Firmware update	N - via ChamSys consoles only	N - via ChamSys consoles only	N - via ChamSys consoles only	N - via ChamSys consoles only	N - via ChamSys consoles only
Saving and recalling User presets	Y - via Web server only	Y - via Web server only	Y - via Web server/Node display	Y - via Web server/Node display	Y - via Web server/Node display
Lock / unlock node	Y - via Web server only	Y - via Web server only	Y - via Web server/Node display	Y - via Web server/Node display	Y - via Web server/Node display

Firmware Function	GW20	GW21	GN2	GN5	GN10
LTC and MIDI Timecode to/from 3rd Party Consoles	N	N	N	Y - Art-Net Timecode only	Y - Art-Net Timecode only
MIDI notes to/from 3rd Party Consoles	N	N	N	N	N
10Scene Gateway functionality with 3rd Party Consoles	N	N	N	N	N

Chapter 19. GeNetix Firmware Release Notes

Version 2.00

- Implemented detection of multiple data sources on a single port, the affected port on the GeNetix product will turn red (Home Screen and Port LED).
- Add support for Merging (HTP, LTP, Highest IP and Lowest IP options) this can be configured in the net manager ports menu.
- Added in menu option for Timecode input port selection.
- Add support for Identify to work when the device is PIN locked.
- Add a "Reset Configuration" option for resetting individual configurations.
- Add support for a Lost Data mode of "Scenes Panel" feature where control can pass from the console to the GeNetix device.
- Show Art-Net timecode on the GeNetix device when the Timecode input option is selected.
- Add support for some characters that were not supported for naming, previously only . - _ < and > were supported in port names.
- Added additional scene and panel enable/disable trigger mode options.
- Added 10Scene external control support, 10Scene external control support includes the 10Scene App, MIDI Notes 0...9 and CREP (ChamSys Remote Ethernet Protocol).
- Fix 10Scene Wall Plates not seen by MagicQ when connected via GN5 / GN10. [#0040464](#)
- Fix 10Scene Wall Plates unable to set ID and ID ignored by GN5/10. [#0040465](#)
- Fix 10Scene Wall Plate ID being ignored when connected to GN5/10. [#0040466](#)
- Resolve issue with some GeNetix devices getting stuck in factory test mode.

Version 1.04

- Add support for GeNetix GN5 & GN10.

Version 1.01

- Initial release version.

Chapter 20. Firmware Upgrade

GeNetix network nodes can be upgraded from MagicQ and QuickQ software.

Firmware upgrade is only supported over ChamNet, not over USB. Firmware upgrade can be carried out from the free MagicQ PC/Mac software, and from MagicQ and QuickQ consoles.

MagicQ and QuickQ software packages contain the latest firmware for GeNetix devices. Update the installed MagicQ or QuickQ software to the latest release to access the latest GeNetix firmware versions.

In MagicQ PC on the top toolbar click on Setup and select Net Manager to open the Net Manager window. Detected GeNetix devices will be shown in the window. Click on the device to be upgraded and press the UPGRADE DEVICE soft button. Select the required firmware version. MagicQ only shows firmware versions valid for the chosen device.

In order to upgrade a GeNetix device it must be in the same IP address range as the MagicQ system. If MagicQ is using a 2.x.x.x IP address then ensure the GeNetix device is also using a 2.x.x.x IP address.

If the Device Manager title bar indicates "INVALID NET" ensure the IP address selected for MagicQ in Setup, View Settings, Network, IP Address, is set to the IP address of a valid network adapter on the PC/Mac/Linux system.

The 10Scene Store, GW20, GW2I, and GN2 firmware is named firmware_5000_XXXX, where "XXXX" indicates the version number. For the GN5 and GN10 the firmware is named firmware_5100_XXXX where "XXXX" indicates the version number. Firmware is stored in Documents\MagicQ\firmware.

GeNetix nodes start up in a boot firmware, indicated by a red message displayed on the front panel screen, before starting the main application firmware. During firmware upgrade the nodes return to the red boot state, indicated by a "downloading" on screen message. If for any reason the main application fails to upgrade then the GeNetix node will again return to the boot state and can be upgraded again.

Glossary

Below are a few commonly used terms to help with getting started with GeNetix Nodes.

10Scene

The 10Scene range comprises wall panels and interfaces allowing a GN5 or GN10 to be controlled from a simple wall panel or the 10Scene App.

Art-Net™

Art-Net is a network protocol that allows [DMX](#) to be carried over an Ethernet network. Art-Net™ is designed by and copyright Artistic Licence Holdings Ltd.

DMX or DMX512

DMX is the standard way for a console to communicate with lighting fixtures. DMX cables should be used to carry the data, other types of cable may cause flickering and other problems. QuickQ can output DMX directly and can also transmit DMX data over an Ethernet network using a protocol such as [Art-Net](#), or [sACN](#).

DMX Address

Each fixture has its own starting DMX address, which is different for every fixture on a single [DMX universe](#).

DMX Channels

DMX512 has 512 individual DMX channels on each [universe of DMX](#).

DMX Universe

A collection of 512 DMX Channels is referred to as a Universe of DMX.

IP address

All Ethernet devices have an IP address to identify them. IP addresses take the form A.B.C.D, where ABCD are numbers between 0 and 255 with dots in between them. Typical Lighting Networks will use either a 10. or 2. IP address scheme for the first Part of the IP address (this would be letter A in the previous example). GeNetix nodes ship with a 10. IP address by default. When setting up a network all the devices on the network should have a different IP address, but they should all be within the same range (for example 2. or 10.) and on the same subnet GeNetix devices only use IPv4 addresses.

MIDI

MIDI is an acronym that stands for Musical Instrument Digital Interface. It is a way to connect devices that make and control sound, such as synthesisers and sequencers. It can be used to trigger lighting from an audio device such as a digital keyboard.

Remote Data Management (RDM)

RDM is an extra protocol added to DMX. It does not require any extra cabling than normal [DMX](#) and allows fixtures to communicate with the console.

sACN

sACN is a protocol used to transmit [DMX](#) data over Ethernet. sACN can be trickier to get working

than [Art-Net](#) but can work better than Art-Net when there is large amounts of DMX data (>40 universes) on a network.

Appendix A: DMX, Ethernet and Art-Net

DMX

DMX data is transmitted in a serial form. This means that there is one cable carrying the data, which is sent bit by bit (a bit is a 1 or 0), one after another. The entire transmission of DMX data for a DMX universe is known as a DMX Packet.

The DMX Packet consists of a start code and 512 channel levels.

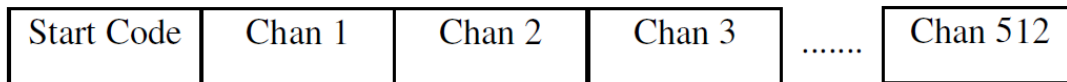

The start code for DMX is generally 0. The channel section contains the level for that channel.

Ethernet

Ethernet is the technology used to connect computers on a network. Most computers use a protocol called TCP/IP (Transmission Control Protocol Over Internet Protocol) to communicate over an Ethernet network.

Ethernet transmits the IP address (address of a computer on the network) of the sending computer, followed by the IP address of the receiving computer, followed by the data. The IP addresses allow the data to be routed to the correct computer.

On a typical office network, computers will have an IP address of 192.168.1.x, where x is between 0 and 254 (255 is a reserved address). These IP addresses are generally assigned dynamically by the Router on the network using a protocol called DHCP.

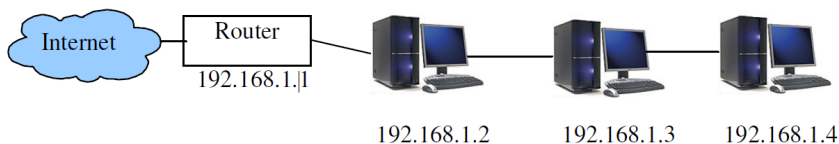

The computers use a subnet mask of 255.255.255.0. This specifies which range of IP addresses are on the local network. In the example above 255.255.255.0 specifies a range of from 192.168.1.0 to 192.168.1.255 which is a total of 256 addresses.

Art-Net

What Is Art-Net?

Art-Net is a royalty-free communication protocol, developed by Artistic License used to transmit DMX information over a network.

An Art-Net network typically uses the 2.x.x.x or 10.x.x.x IP Address scheme using a subnet of 255.0.0.0. It is important to ensure that Art-Net data using the 2.x.x.x IP address scheme is not routed onto the



internet.

Ideally you should set up a separate network between your QuickQ console and the Art-Net devices.

Unlike normal office networks, the IP address must be in the range 2.x.x.x or 10.x.x.x, where x is between 0 and 255.

The subnet mask must be set to 255.0.0.0. This means configuring the address of each piece of equipment on the network manually. QuickQ products are typically set to 10.x.x.x. from the factory.

Appendix B: FCC Part 15 Notice

This device complies with Part 15 of the FCC rules. Operation is subject to the following two conditions:

- (1) This device may not cause harmful interference; and
- (2) this device must accept any interference received, including interference that may cause undesired operation.

This equipment has been tested and found to comply with the limits for a Class B digital device, pursuant to part 15 of the FCC Rules. These limits are designed to provide reasonable protection against harmful interference in a residential installation. This equipment generates, uses and can radiate radio frequency energy and, if not installed and used in accordance with the instructions, may cause interference with radio and television reception. However, there is no guarantee that interference will not occur in a particular installation. If this equipment does cause harmful interference to radio or television reception, which can be determined by turning the equipment off and on, the user is encouraged to try to correct the interference by one or more of the following measures:

- Reorient or relocate the receiving antenna.
- Increase the separation between the equipment and receiver.
- Connect the equipment into an outlet on a circuit different from that to which the receiver is connected.

You may also consult your local ChamSys Ltd dealer or an experienced radio/TV technician for assistance.

NOTICE: The FCC regulations provide that any changes or modifications not expressly approved by ChamSys Ltd could void the user's authority to operate the equipment.



Appendix C: Disposal and Recycling of Unwanted Consoles

Please be aware that ChamSys products must be disposed of in accordance with the [WEEE disposal and recycling regulations](#). ChamSys products must not be disposed of through normal household waste.

For non-UK customers please contact your local distributor.

For UK customers, please contact us on +44 (0)23 8023 8666, or email [ChamsSys Support](#).

WEEE Producer Registration Number; WEE/FF5605UX.

S

Appendix D: GeNetix Warranty Certificate

Thank you for purchasing a GeNetix Product.

All GeNetix Devices come with a two-year warranty, for warranty terms and conditions, please visit our website at <https://www.chamsys.co.uk>

For Warranty claims please contact the dealer you purchased the console from. If you are based outside of the UK please contact your local dealer. Your local dealer can be located here: <https://secure.chamsys.co.uk/contact>